

INSTRUCTION MANUAL FUNCTION-DECODERS

and LIGHTING BOARDS

MX671N

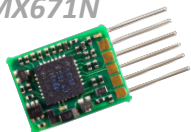

MX689N18

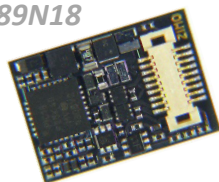

MX675V

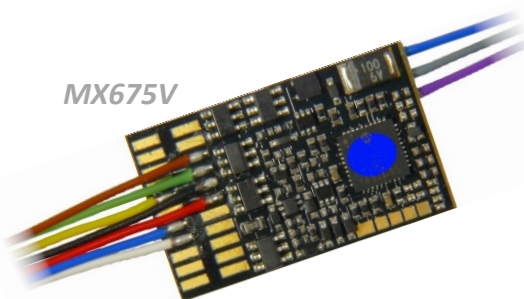

MX686D

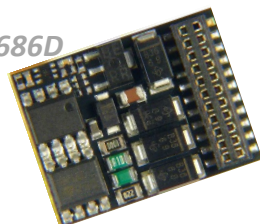

MX685P16

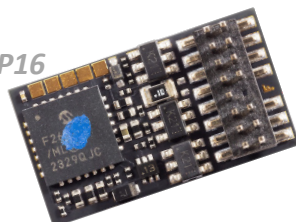

MX671, MX671R, MX671N
MX681, MX681R, MX681N

MX685, MX685R, MX685P16
MX686D, MX686

MX675V, MX675VP22, MX676VD
MX687V, MX687W, MX687WD

MX688N18
MX689N18

Printed in GREY are the types
that are discontinued.

LIPLDHW1, LIPLDHY1

LIPLDNW1, LIPLDNY1

LIPL1N18

LIPLDL ... Gauge 0

LIPLDG ... Large Scale

LIPLDNx1

LIPL1N18

LIPLDHx1

Type spectrum only shown in extracts.

MX6055L

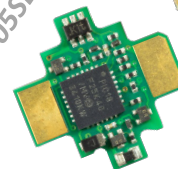

MX605FL

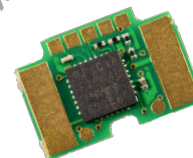

EDITION:

First edition	---	2011 08 15
		2012 08 15
		2015 01 25
		2015 02 05
MX688N18 supplement	---	2015 11 16
Swiss Mapping	---	2016 06 23
		2018 05 25
		2018 07 11
		2022 01 18

First edition of the combined instruction manual
MX function decoders and lighting boards --- 2023 04 27

2026 02 20

Content

1.1	Function decoders.....	3
1.2	Lighting boards.....	4
2	<i>Technical data, connection diagrams.....</i>	<i>5</i>
3	<i>The CVs in DCC mode.....</i>	<i>14</i>
3.1	Basic Settings	14
3.2	Decoder-ID	14
3.3	Manufacturer identification, SW-Version.....	14
3.4	The (first) vehicle address(es) in digital mode	15
3.5	The SECOND address(es) in use as a function decoder.....	16
3.6	Analog Operation	17
3.7	"Virtual" motor control, acceleration, braking.....	17
3.8	Function Mapping (FIRST address) according to NMRA-DCC.....	19
3.9	Function Mapping (SECOND address) according to NMRA-DCC.....	20
3.10	"Unilateral light suppression"	20
3.11	The „Swiss Mapping“.....	20
3.12	Dimming and fading, direction bit on outputs.....	22
3.13	The blink effect	23
3.14	F1 Pulse Chains (Only for old LGB products).....	23
3.15	Effects for function outputs ("new level" as of SW version 40.19)	24
3.16	Configuration of Electric Uncouplers	26
3.17	SUSI-Interface and Logic Level Outputs.....	26
3.18	Servo Configuration.....	26
3.19	The Low Voltage for Function Outputs (Only Function-Decoders MX675, MX676).....	27
4	<i>CV - overview; CVs in numerical order.....</i>	<i>28</i>
5	<i>Calculation of the long second loco address.....</i>	<i>35</i>
6	<i>Service Notes</i>	<i>36</i>

Overview of types and type-dependent data

1.1 Function decoders

	<i>MX671, MX671R, MX671N</i>	<i>MX675V</i>	<i>MX676VD</i>	<i>MX685P16 MX685, MX685R</i>	<i>MX686D</i>	<i>MX689N18</i>
Dimensions (mm)	10.5 x 8 x 2.2	25 x 15 x 4	26 x 15 x 3.5	20 x 11 x 3.5	20.5 x 15.5 x 3.5	14 x 9.5 x 2.1
<i>Connections</i> <small>Wires and/or normed plugs</small>	<i>9 Wires</i> <small>with NEM-652, or NEM-651(-Pins)</small>	<i>10 Wires</i>	<i>21MTC</i>	<i>PluX-16</i> <small>7 Wires/ with NEM-652</small>	<i>21MTC</i>	<i>Next18</i>
Continuous Current	0.7 A	1.8 A	1.8 A	1.0 A	1.2 A	0.7 A
Function Outputs <small>(amplified)</small>	6	12	10/6	8	8	4
Current limit. Fu. Out. <small>(in total)</small>	0.85 A	1.2 A	1.2 A	1.2 A	1.2 A	0.85 A
Logic Level Outputs <small>(UNamplified)</small>	-	2, alt. to SUSI	2/6 (2 alt. to SUSI)	2, alt. to SUSI	4, 2 alt. to SUSI	4, 2 alt. to SUSI
Servo Outputs	-	2, alt. to SUSI	2, alt. to SUSI	2, alt. to SUSI	2, alt. to SUSI	2
SUSI	-	yes	yes	yes	yes	yes
Direct Energy Storage	yes (25 V)	yes (16 V)	yes (16 V)	-	yes	-
Low Voltage Outputs.	-	adjustable	adjustable	-	-	-

1.2 Lighting boards

	LIPLDHW1	LIPLDHY1	LIPLDNW1	LIPLDNY1	LIPL1N18	LIPLDOW1	LIPLDOEW	LIPLDOY1	LIPLDOEY1	LIPLDGW1	LIPLDGEW1	LIPLDGY1	LIPLDGEY1
Dimensions (mm)	296 x 8.2 x 2,8 <i>breakable</i>	296 x 8.2 x 2.8 <i>breakable</i>	166 x 8.2 x 2.8 <i>breakable</i>	166 x 8.2 x 2.8 <i>breakable</i>	208 x 12 x 4.5 <i>breakable</i>	planned Type	planned Type	planned Type	planned Type	380 x 18 x 7.3 <i>breakable</i>	685 x 18 x 7.3 <i>breakable</i>	380 x 18 x 7.3 <i>breakable</i>	685 x 18 x 7.3 <i>breakable</i>
<i>Vehicle Size</i>	H0, TT	H0, TT	N, TT	N, TT	N, TT, short H0 (00)	Gauge 0	Gauge 0	Gauge 0	Gauge 0	G, 1, 2	G, 1, 2	G, 1, 2	G, 1, 2
Interface for Decoder	no Decoder integriert	no Decoder integriert	no Decoder integriert	no Decoder integriert	Next18 max. decoder length 22mm	no decoder integrated	no decoder integrated	no decoder integrated	no decoder integrated	no decoder integrated	no decoder integrated	no decoder integrated	no decoder integrated
Number of light units (Interior lighting)	14	14	14	14	10 <small>2 LEDs each - cool white/yellow</small>					9	9	16	16
Spacing of the light units	22 mm	22 mm	12 mm	12 mm	22 mm					45 mm	45 mm	45 mm	45 mm
Switchable light. groups	7 (FO2 - FO8)	7 (FO2 - FO8)	7 (FO2 - FO8)	7 (FO2 - FO8)	4 (FO1 - FO4)					5 (FO2 - FO6)	5 (FO2 - FO6)	8 (FO2 - FO9)	8 (FO2 - FO9)
Color of interior lighting	neutral white	yellow	neutral white	yellow	manually adjustable					neutral white	neutral white	yellow	yellow
Fu. Outp. on solder pads	3 (FOf, FOr, FO1)	3 (FOf, FOr, FO1)	3 (FOf, FOr, FO1)	3 (FOf, FOr, FO1)	2 (FOf, FOr)					4 (FOf, FOr, FO1, FA10)	4 (FOf, FOr, FO1, FA10)	4 (FOf, FOr, FO1, FA10)	4 (FOf, FOr, FO1, FA10)
Type of additional FOs	Constant current source (8 mA)	Constant current source (8 mA)	Constant current source (5 mA)	Constant current source (5 mA)	amplified (open collector)					amplified, max. 2 A (open collector)	amplified, max. 2 A (open collector)	amplified, max. 2 A (open collector)	amplified, max. 2 A (open collector)
Internal energy storage	300 µF / 16 V	300 µF / 16 V	150 µF / 16 V	150 µF / 16 V	150 000 µF / 5.4 V					330 000 µF / 9 V	330 000 µF / 9 V	330 000 µF / 9 V	330 000 µF / 9 V
External energy storage	16 V / max. 15 000 µF	16 V / max. 15 000 µF	16 V / max. 15 000 µF	16 V / max. 15 000 µF	no					no	no	no	no
Motor output	no	no	no	no	depending on decoder					no	no	no	no
Speaker output	no	no	no	no	YES (for sound-decoders)					no	no	no	no
Low voltage	no	no	no	no	no					YES, adjust. to 1.5 V or 5 V	YES, adjust. to 1.5 V or 5 V	YES, adjust. to 1.5 V or 5 V	YES, adjust. to 1.5 V or 5 V

2 Technical data, connection diagrams

Allowable range of the running voltage on the rail min. 10 V

MX671, MX681	max. 35 V
MX685, MX686, MX687, MX688, MX689 ..	Digital-, DC-Analog Operation.. max. 35 V
Lighting Boards.....	max. 35 V
MX685, MX686, MX687, MX688, MX689 ..	AC-Analog Operation Impulse max. 50 V

Maximum continuous total current*) MX671, MX671R, MX671N, MX681	0.7 A
MX688N18, MX689N18	0.7 A
MX685, MX685R, MX685P16	1.0 A
MX673P22, MX686, MX686D, MX687	1.2 A
MX675V, MX675VP22, MX676VD	1.8 A

Operating temperature..... - 20 bis 100 °C

Dimensions see chapter 0 "Overview of types and type-dependent data"

*) The short circuit protection is carried out for the total current of all outputs. Use the "soft start" option (i.e. CV #125 = 52) to prevent cold-start problems of light bulbs (in-rush current interpreted as a short circuit, which leads to the output being turned off!

Software - Update:

ZIMO decoders can be updated by the user, provided that one of the following update devices is at hand: ZIMO decoder update-module **MXULF** (since 2011), system-cab **MX31ZL** or **command station MX10**. The updating process is carried out via a USB stick (MXULF, MX31ZL / MX10) or a PC with Windows operating system and the program ZIMO Firmware Flasher (within the ZIMO Sound Programmer **ZSP**).

The same hardware together with the program ZSP is also used to load sound projects into the decoder.

There is **no need to remove the decoder or to open the locomotive**. Just set the locomotive on a track section connected to the update module and start the update with the computer or other equipment mentioned above.

Connection diagram MX671, MX671R Connection Side

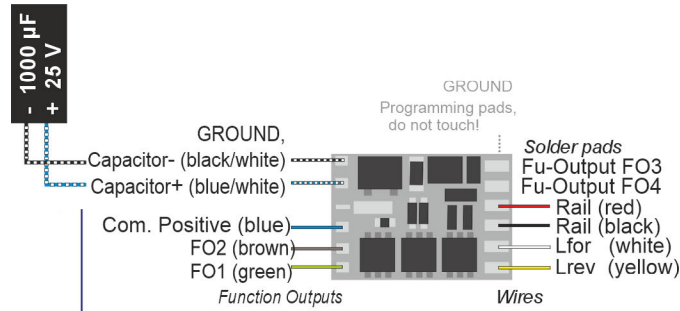

Capacitors or Goldcap-Series can be connected as energy storage device (25 V Dielectric strength, **unlimited capacity**).
if driving voltage ALWAYS < 25 V, is sufficient
Dielectric strength according to the driving voltage.

Connection diagram MX671N Controller Side

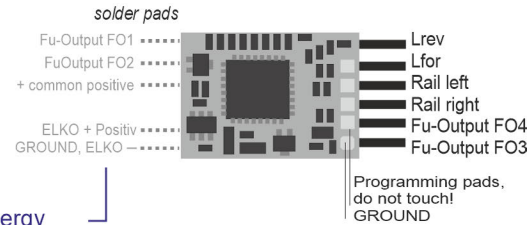

Connection diagram MX681, MX681R, MX681F Connection Side
(= where wires are soldered on!)

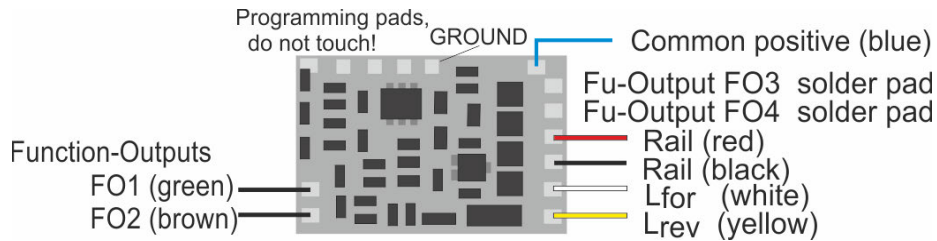

Connection diagram MX681, MX681R, MX681F Controller Side
(= where wires are soldered on!)

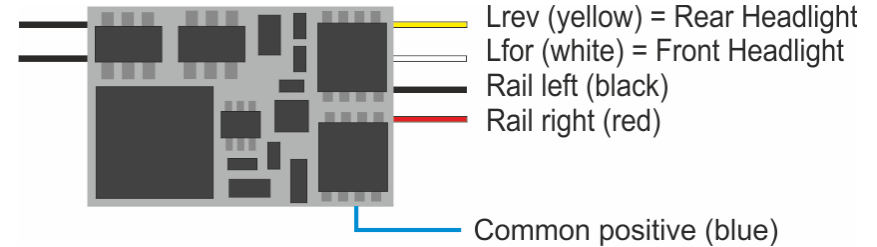

Connection diagram MX681N Controller Side
(This is also the proper plug-in position!)

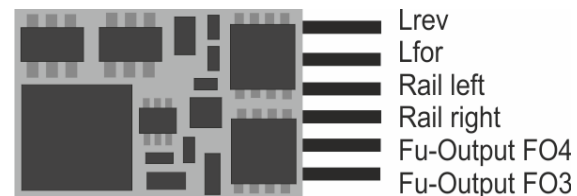

Connection diagram **MX685** Top Side wired

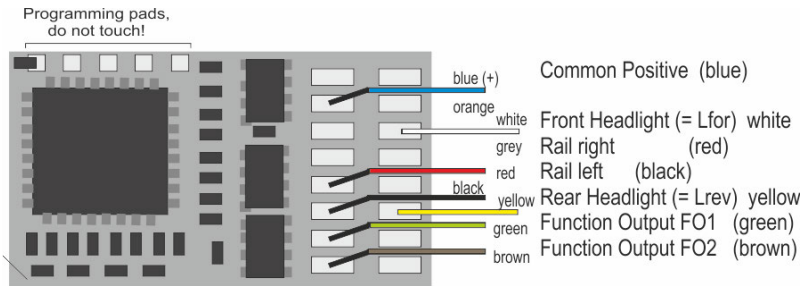

Connection diagram **MX685P16** Pad assignment

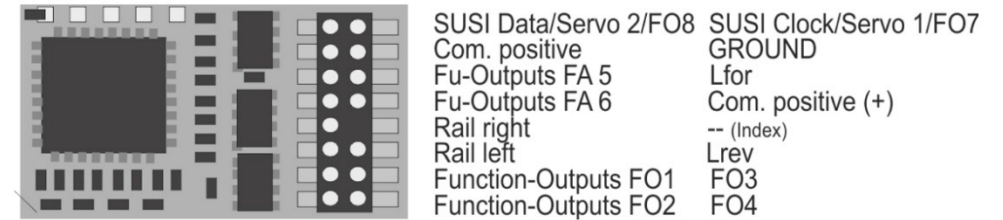

Connection diagram **MX686 (bis 2012)** Top Side wired
(Based on MX631-Series)

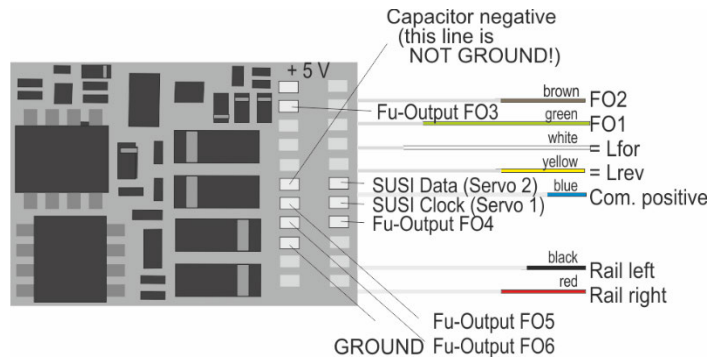

Connection diagram **MX686D (bis 2012)** Bottom Side
(Based on MX631-Series)

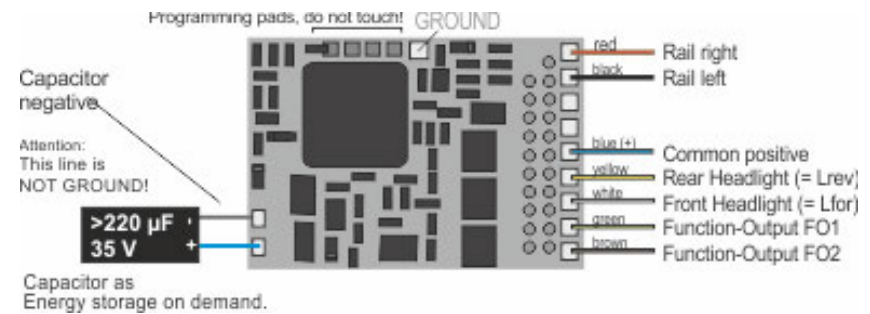

Connection diagram **MX686D (bis 2012)** Top Side wired

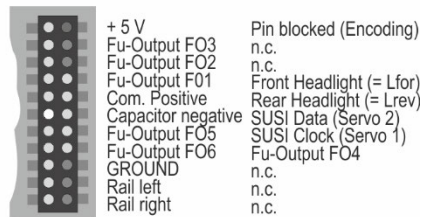

Conn. diagram MX686 (from 2013) Top Side
(Based on MX634-Series)

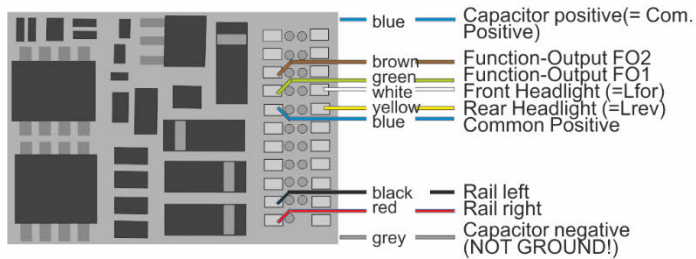

Connection diagram MX686C, D
(From 2013)
Top Side View (Based on MX634-Series)

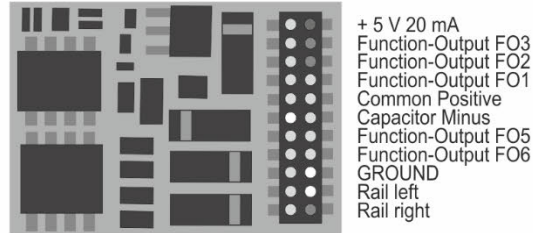

with CV # 8 = 3 > MX686D is converted to MX686C (i.e. Outputs FO3, FO4 become Logic Level Outputs)
with CV # 8 = 4 > MX686C is converted to MX686D (i.e. Outputs FO3, FO4 become „normal“ Function-Outputs)

MX686 Bottom Side View
(From 2013, based on MX634-Series)

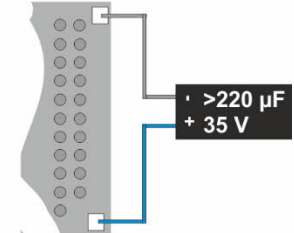

Connection diagram MX687V, W Top Side View

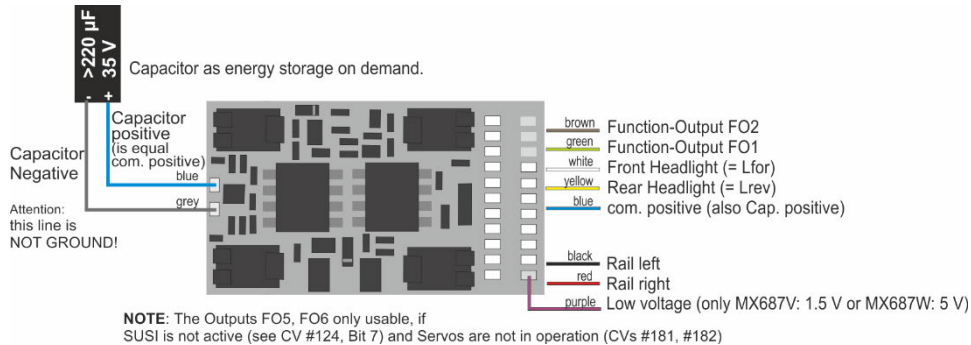

Connection diagram MX687V, W Bottom Side View

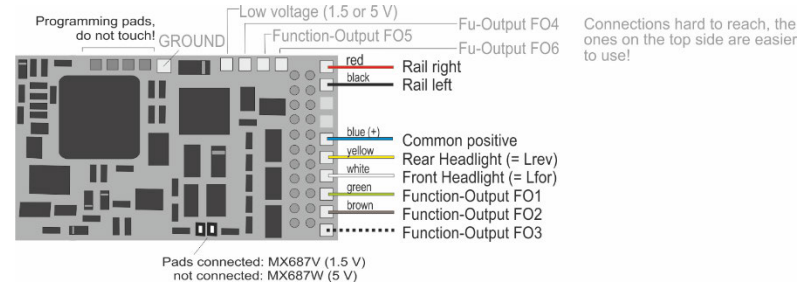

Connection diagram MX687D, VD, WD Top Side View

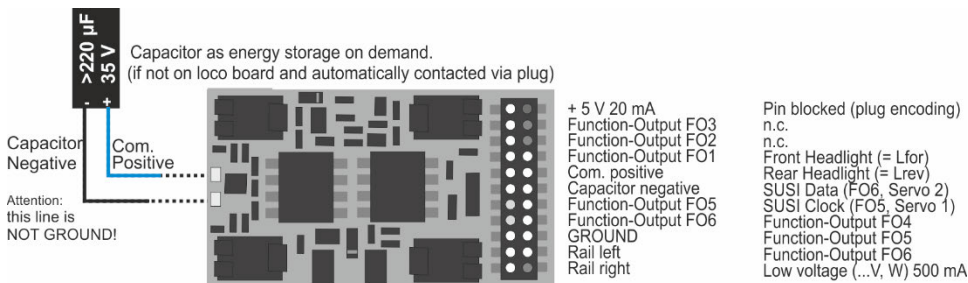

Connection diagram MX687D, VD, WD Bottom Side View

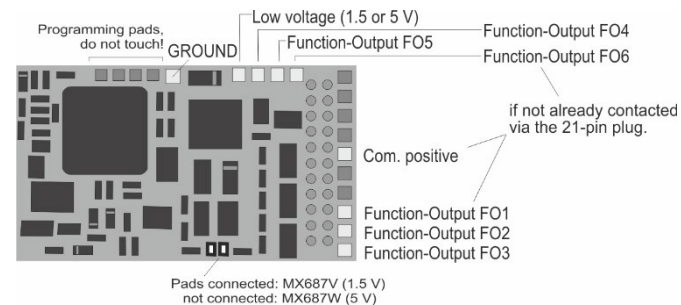

MX675V wired
Top Side

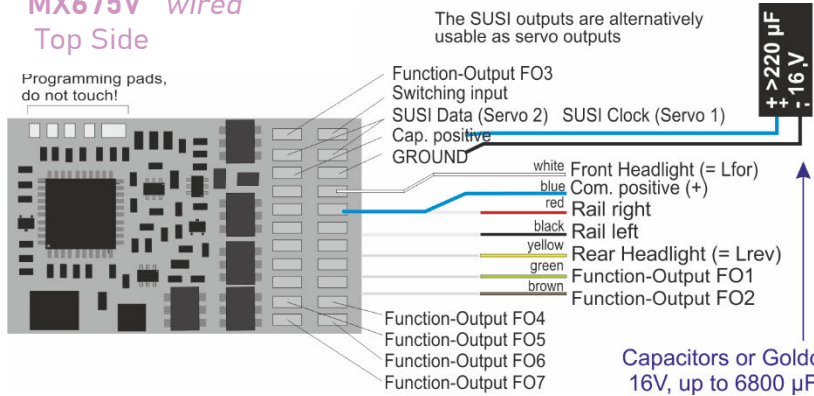

MX675VP22 Top Side (with PluX22)

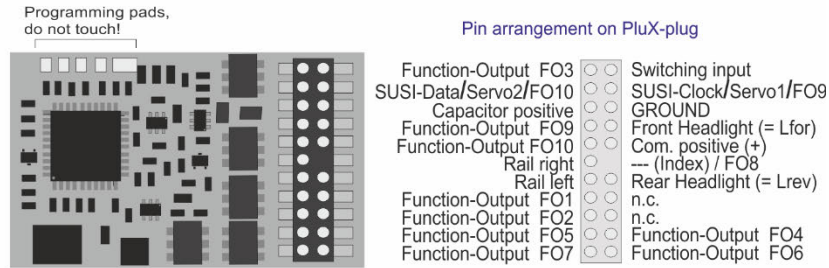

MX676VD Top Side

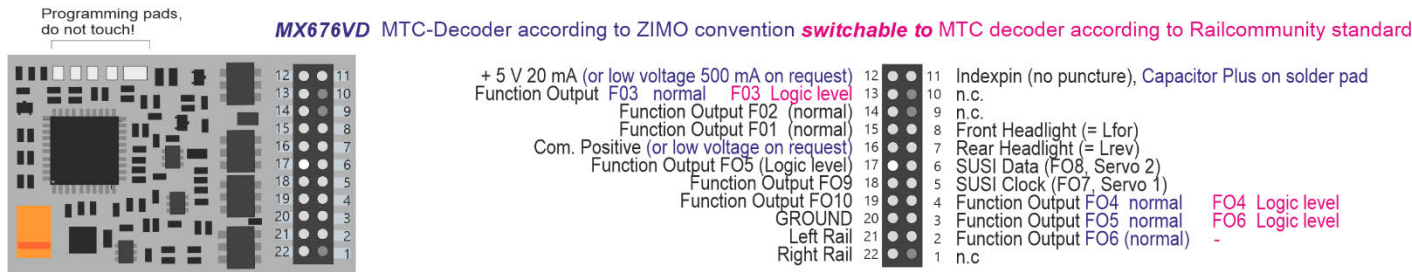

The pin assignment of type MX676VD corresponds to the usual convention for ZIMO decoders (such as MX634D or Sound-Decoder MX644D) With the switchover the pin assignment corresponds to a **type C** (e.g. MX644C) and with this the Norm RCN-121 of VHDM (RailCommunity)

Conversion of the two types into each other via CV #8 possible at any time!

with CV # 8 = 3 > **MX676VD** is converted to **Typ C**, i.e. pins 13, 4 (Outputs F03, F04) become logic level function outputs, Pin 3 becomes output F06 as logic level function output, Pin 2 is not used

with CV # 8 = 4 > **MX676V as Typ C** becomes **MX676VD** again, i.e. Pins 13, 4 Outputs F03, F04) become „normal“ function outputs*, Pin 3 becomes output F05 as „normal“ function output, Pin 2 becomes output F06 as „normal“ function output

*) „normal“ function output, also referred to as "amplified" output = Suitable for direct connection of a consumer (Light, smoke generator, ...) between any positive voltage (e.g. according to the positive pole of the decoder) or low voltage and this output. „Logic level output“ = Output accepts voltage level 0 V and 5 V depending on switching state (0, 1), external amplification necessary, possibly directly suitable for LED.

MX675V, ...P22, MX676VD Bottom Side

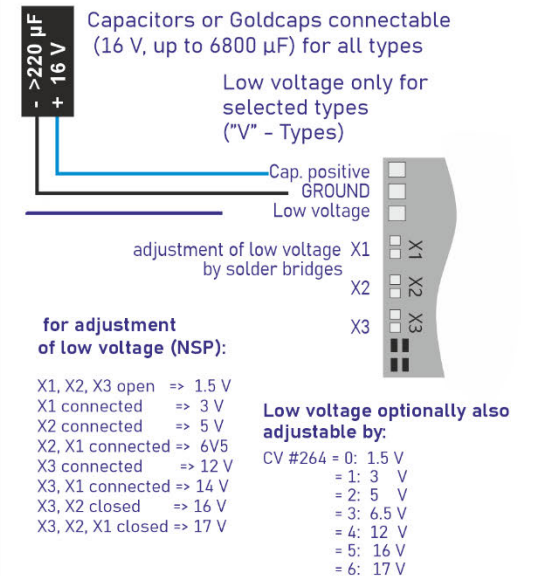

It is convenient and recommended to use only one of the two possibilities for setting the low voltage; But it is also possible to combine both methods: if the value in CV #264 is read binary (for example 3 = 0000 0011) the "1" are the same as connected solder bridges (so in case of 3 like X1 and X2). The low voltage results from the OR-connection of the solder bridges (X1, X2, X3) and the bits 0, 1, 2 of CV #264. So the combination always results in a higher voltage, for example CV #264 = 3 AND solder bridge Xx results in 17 V.

Connection diagram **MX688N18** Plug Side View (Next-18)
(Replaced by MX689N18)

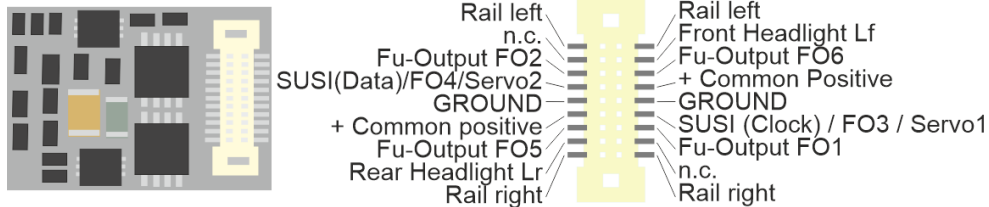

Note: FO3, FO4 as logic level output to SUSI pins, if CV #124, Bit 7 = 1

Connection diagram **MX689N18** Bottom Side View (Next-18)



Connection diagram **MX689N18** Plug Side View (Next-18)

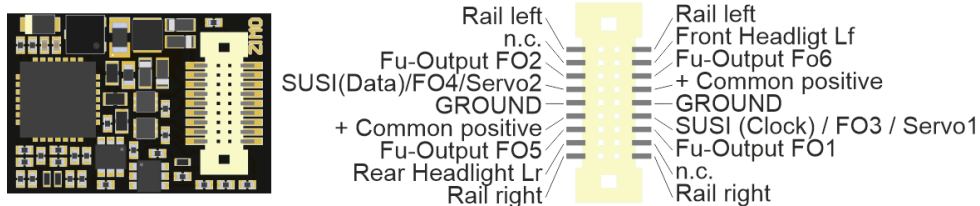

Note: FO3, FO4 as logic level output to SUSI pins, if CV #124, Bit 7 = 1

Connection diagram **MX605SL and MS605FL - KATO models**

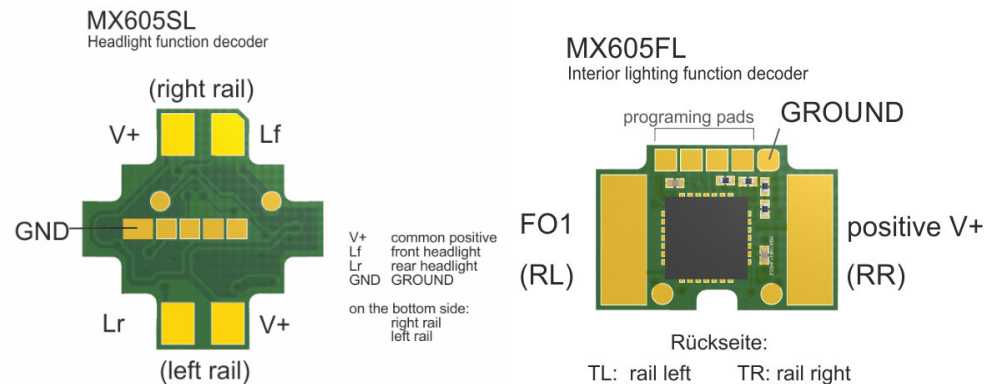

KATO multiple units (such as the ICE-4, BR 425, etc.) are equipped not only with the dedicated function decoders for the headlights and interior lighting, but also with the actual (main) decoder, e.g. the MS560 sound decoder.

The CV values of the MX605SL and MX605FL can be set, but cannot be read out.

The decoder does not provide any feedback capability.

Configuration must be carried out individually on the programming track.

Connection Diagram LIPL1N18 (208 mm long)

Top Side (facing the roof) CAD

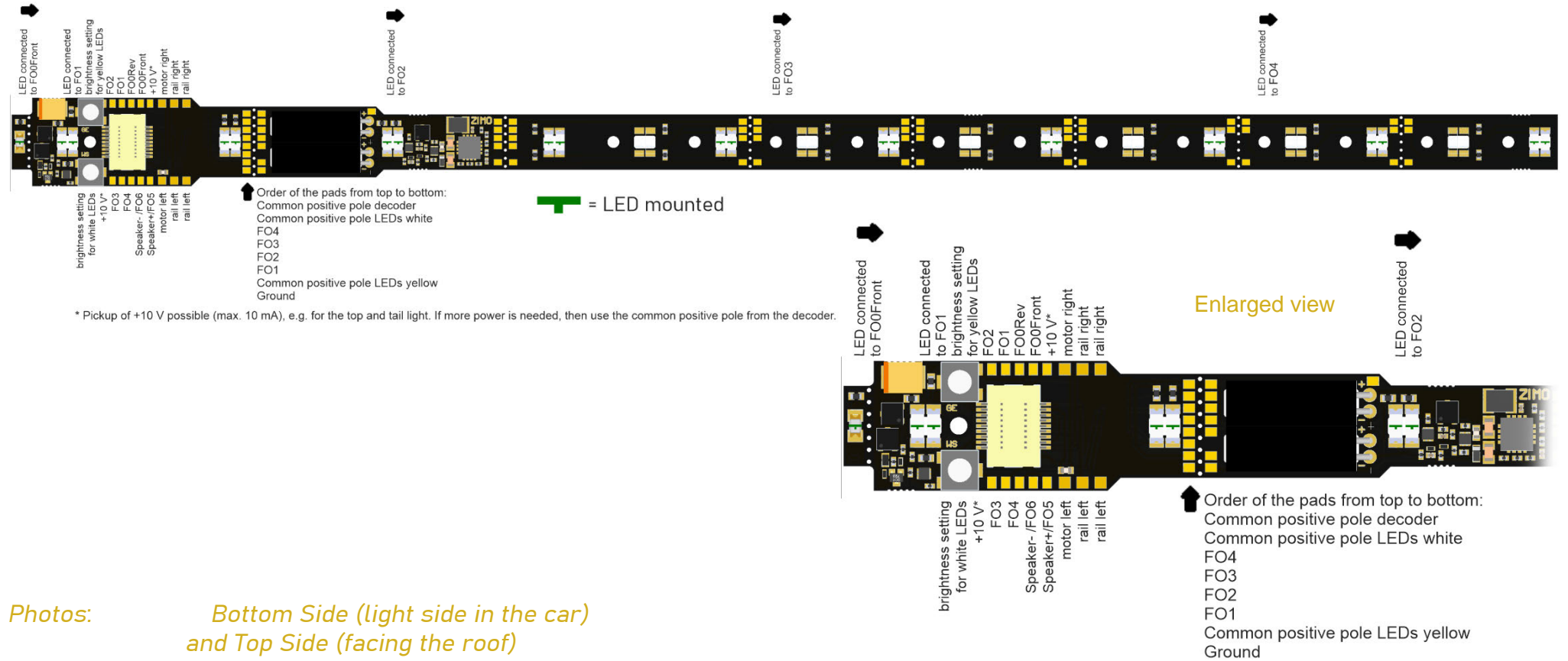

* Pickup of +10 V possible (max. 10 mA), e.g. for the top and tail light. If more power is needed, then use the common positive pole from the decoder.

Photos: Bottom Side (light side in the car) and Top Side (facing the roof)

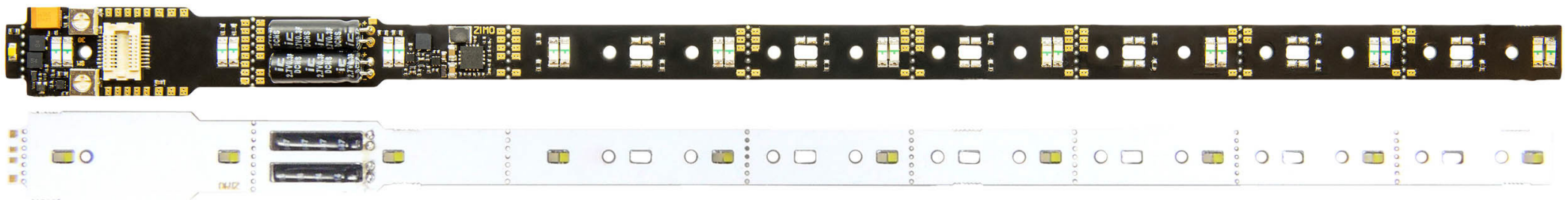

Connection Diagram LIPLDGW1 (380 mm long)
 = Main Board of LIPLDGEW1 (685 mm long)

For Large Scale

resp. LIPLDGY1 (380 mm long)
 = Main Board of LIPLDGEY1 (685 mm long)

Top Side (facing the roof)

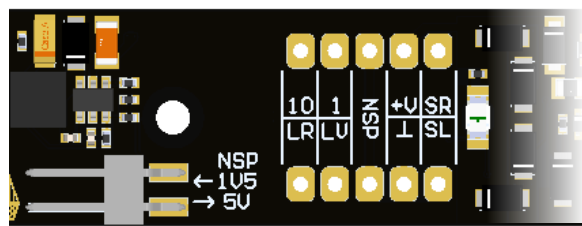

Enlarged view
 with legible labeling

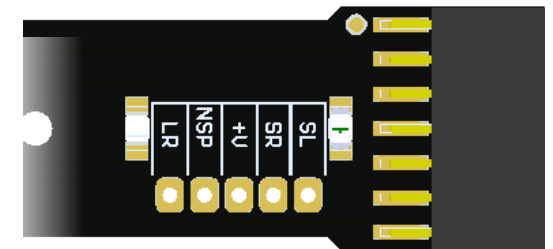

Connection Diagram from the plug-in expansion board LIPLDGEW1
 resp. LIPLDGEY1

LIPLDGE_x1 = LIPLDG_x1 + expansion board

Top Side (facing the roof)



Enlarged View
 with legible labeling

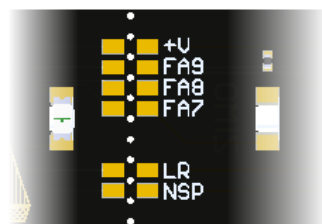

3 The CVs in DCC mode

3.1 Basic Settings

CV	Denomination	Range	Default	Description
#27	BRAKE-MODI Position-dependent stopping ("before the red signal") or slow driving by means of "Asymmetric DCC - Signal" ("Lenz ABC").	0, 1, 2, 3	0 = ABC not active, HLU active (!),	Bit 0 and Bit 1 = 0: ABC is NOT active, no stop. Bit 0 = 1: ABC stop occurs when right rail (in direction of travel) has higher voltage than left rail. This (CV #27 = 1) is the usual ABC application Bit 1 = 1: ABC stop occurs when left rail (in direction of travel) has higher voltage than right rail. If Bit 0 or Bit 1 = 1 (only one, not both): Stopping is direction-dependent, i.e. only in the direction of travel towards the signal, passage in the opposite direction. Bit 0 and Bit 1 = 1 (so CV #27 = 3): Stopping takes place independent of direction of travel in case of asymmetry
#28	RailCom Configuration	0 - 3 64 - 67	3	Bit 0 - RailCom Channel 1 (Broadcast) 0 = OFF 1 = ON Bit 1 - RailCom Channel 2 (Data) 0 = OFF 1 = ON
#29	Basic settings	0 - 63	14 = 0000 1110 so bit 3 = 1 ("RailCom switched on), and Bits 1,2 = 1 (28 or 128 speed steps, and autom. analog operation)	Bit 0 - Directional behavior 0 = normal, 1 = inverted Bit 1 - Speed step system (number of speed steps) 0 = 14, 1 = 28/128 speed steps Bit 2 - Automatic switching to analog mode 0 = off, 1 = switched on Bit 3 - RailCom (bi-directional communication) 0 = off 1 = on Bit 4 - Selection of speed characteristic 0 = three-point charact. acc. to CV #2, #5, #6 1 = free characteristic according to CV #67 - #94 Bit 5 - Selection of vehicle address (DCC) 0 = "Short" address according to CV #1 1 = "Long" address according to CVs #17 + #18
#144	Programming and update locks NOTE: the programming lock in CV #144 does not affect CV #144 itself; this makes it possible to override the programming lock.	0, 64, 128, 192	0	= 0: no programming and update lock. Bit 6 = 1: the decoder cannot be programmed in "Service mode": Protective measure against accidental reprogramming and deletion. NOTE: Programming in "Operational mode" ("On-the-main") is not locked (because this is done in the operational sequence and specifically an address is targeted) Bit 7 = 1: Locking of software update via MXDECUP, MX31ZL or other means.
#112	Special ZIMO configuration bits	0 - 255	2	Bit 1 = 0: Normal acknowledgement in "Service mode"; i.e. switching on the motor and light outputs. = 1: High frequency current pulses for acknowledgement as a measure if motor/light is not sufficient.

3.2 Decoder-ID

CV	Denomination	Range	Default	Description
#250, #251, #252, #253	Decoder ID, of which CV #250 = Decoder type (See chapter 0 Overview of types and type-dependent data) CV #251 and CV #252 and #253 = actual Serial number	Read only	-	The decoder ID (= serial number) is written automatically during production: the first byte and half of the second is a code for the decoder type, the rest is a sequence number. The decoder ID is needed mainly for registration procedures at digital command stations and in connection with the load code for "coded" sound projects (see CVs #260 to #263).

3.3 Manufacturer identification, SW-Version

CV	Denomination	Range	Default	Description
#8	Manufacturer identification and HARD RESET by CV #8 = 8 or CV #8 = 0	No write access 145 is always read out as ZIMO identifier Pseudo programming see description right	145 (= ZIMO)	Reading this CV results in the manufacturer number assigned by the NMRA; for ZIMO "145" ("10010001"). At the same time this CV triggers various reset operations by "pseudo-programming". "Pseudo-programming" means: programmed value is not stored, but a defined action is triggered. CV #8 = "3" → 21MTC decoder F03, F04 logic level CV #8 = "4" → 21MTC decoder F03, F04 amplified CV #8 = "5" → 21MTC decoder F05, F06 logic level CV #8 = "6" → 21MTC decoder F05, F06 amplified CV #8 = "8" → HARD RESET (NMRA standardized); all CVs assume values of the last active CV set or sound project, or (if no such set was activated) the default values of the CV table. CV #8 = "0" → Default values of the CV table Further possibilities, if "CV sets" are available.
#7	SW version number See also CV #65 Subversion number	Read only	-	Reading this CV gives the version number of the software (firmware) currently loaded in the decoder. CV #7 = the number of the " main version". CV #65 = number of the subversion In addition, CV #7 is used to use digital systems with limited number space (example: old Lokmaus) for programming Ones digit = 1: Subsequent programming value + 100 = 2: ... + 200 Tens digit = 1: following CV number + 100 etc. = 9: ... + 900
#65	SW-Subversion number	Read only	-	If there are any subversions to the SW version in CV #7, these will be read from CV #65; thus, total SW version from CVs #7 & #65 (e.g. 28.15).

3.4 The (first) vehicle address(es) in digital mode

As delivered, decoders are usually set to **address 3, i.e. CV #1 = 3**, for both DCC operation and MM operation. Operation at this address is fully possible, but it is recommended to select another address as soon as possible.

In DCC operation, the address space goes beyond the range of a single CV, namely up to 10239. For addresses from 128, the two CVs #17 & #18 are used. CV #29, bit 5 determines if the "short" address in CV #1, or the "long" one in CVs #17 & #18 is valid.

-> Common digital systems (possibly with the exception of very old or simple products) manage the involved CVs and CV #29, bit 5 themselves when writing in the address (= "addressing"), so the user does not have to deal with the type of coding.

CV	Denomination	Range	Default	Description
#1	Primary (short) Address	DCC: 1 - 127 MM: 1 - 255	3	The "short" vehicle address (DCC, MM). In case of DCC operation: The vehicle address according to CV #1 is only valid if CV #29 (basic settings), bit 5 = 0. Otherwise, the address according to CV #17 & #18 is valid, so if CV #29, Bit 5 = 1.
#17 + #18	Extended (long) address	128 - 10239	192/128	The "long" vehicle address (DCC), if an address of 128 or more is desired; The vehicle address according to CVs #17 & #18 is valid, if CV #29 (basic settings), bit 5 = 1.
#29	Basic settings	0 - 63	14 = 0000 1110 so bit 5 = 0 ("short" address)	Bit 0 - Directional behavior 0 = normal, 1 = reverse Bit 1 - Speed step system (number of speed steps) 0 = 14, 1 = 28/128 speed steps Bit 2 - Automatic switch-over to analog operation 0 = off, 1 = on Bit 3 - RailCom (bi-directional communication) 0 = off 1 = on Bit 5 - Selection of vehicle address (DCC) 0 = "short" address according to CV #1 1 = "long" address according to CVs #17 & #18

Decoder-controlled consisting (a.k.a. "Advanced consisting")

Combined operation ("traction operation"), i.e. the joint control of two or more vehicles (usually mechanically coupled) at the same speed can either be organised

- by the digital system (common with ZIMO, does not affect any CVs of the decoder), or
- by the following CVs of the decoders, which can be programmed individually, or (often common in American systems) set appropriately by the digital system.

The following only deals with the second case, i.e. decoder-controlled compound operation.

CV	Denomination	Range	Default	Description
#19	Consist address	0, 1 - 127, 129 - 255 (= 1 - 127 mit inv. Richtung)	0	Alternative consist address If CV #19 > 0: Speed is controlled by consist address (and not by single address in CV #1 or #17 + #18); functions are controlled either by consist address or single address; see CVs #21 + #22. Bit 7 = 1: Driving direction of this vehicle inverted
#20	Extended Consist address	0 - 102	0	"Long" consist address: the value set in CV #20 is multiplied by 100 and added to the value in CV #19, which then gives the consist address. So e.g. CV #20 = 12, CV #19 = 34 is addr. 1234; CV #20 = 100, CV #19 = 00 is addr. 10000 Bit 7 = 1 activates Railcom on second address
#21	Consist addr active for F1 - F8	0 - 255	0	Functions defined here will be controlled by the consist address. Bit 0 = 0: F1 controlled by individual address = 1: by consist address Bit 1 = 0: F2 controlled by individual address = 1: by consist address F3, F4, F5, F6, F7 Bit 7 = 0: F8 controlled by individual address = 1: by consist address
#22	F0 forw., backw. Consist addr active for F9-F12	0 - 255	0	Select whether headlights and/or functions F9 - F12 are controlled via consist address or individual address. Bit 0 = 0: F0 (forw.) controlled by individual address = 1: by consist address Bit 1 = 0: F0 (rev.) controlled by individual address = 1: by consist address Bit 2 = 0: F9 controlled by individual address = 1: by consist address Bit 3 = 0: F10 controlled by individual address = 1: by consist address Bit 4 = 0: F11 controlled by individual address = 1: by consist address Bit 5 = 0: F12 controlled by individual address = 1: by consist address

3.5 The SECOND address(es) in use as a function decoder

The "SECOND address" is the most important special feature of the ZIMO function decoders and lighting boards. It is programmed in

CV #64 (kurz) oder CV #67 + #68 (lang)

Any address can be entered here, but typically the address of the engine is taken: thus, the cars of a train can all be reached via this address of the engine, e.g. to switch on the light with a single keystroke, or more complex operations, as described below (after the table) as an example. If the second address is active (CV#64 >0 or CV#67/68 >0), the direction of travel is the one transmitted by the control center.

CV	Denomination	Range	Default	Description
#64	Short SECOND ADDRESS	1 - 127	0	The "short" second address; it is active when CV #112, Bit 5 = 0.
#67 + #68	Long SECOND ADDRESS	128 - 10239	0	The "long" second address; it is active when CV #112, Bit 5 = 1. NOTE: In contrast to the "first long address", the cab cannot calculate the proper CV values automatically. As a work around, program the desired second address temporarily as the first address. Then read out CVs #17/#18 and enter these values in CVs #67/#68. Program the first address back to the original address, if used*.
#112	Special ZIMO configuration bits	0, 8, 32, 40	2	Bit 1 = 0: Normal "service mode" acknowledgement. = 1: Special "high frequency" acknowledgement; because LEDs typically do not draw enough current for "service mode" acknowledgement. Bit 5 = 0: Select between "short" or = 1: "long" second address

*The calculation is explained on the last page of this instruction manual

The **sample application of the SECOND address** shown below is supported by **CV sets in the function decoders and lighting boards**. However, these CV sets were only integrated into the software of the function decoders (and of course the lighting boards themselves) in 2022 on the occasion of the market launch of the lighting boards, i.e. **from SW version 40.18 (August 2022) onwards**.

The **purpose of the sample application** is a configuration that causes the lighting of all cars to be controlled by an identical address (typically the address of the locomotive), but each by its own function key. For this, first the

SECOND address^{*)} in each car must be programmed to the address of the locomotive,

and then a different CV set must be activated in each car, which assigns the interior lighting of each car to its own function key.

^{*)}The shared SECOND address can also be any other than the locomotive address; of course, the joint control of the carriage lighting is then carried out via this address, not that of the locomotive.

For practical reasons, not the CV values defined by CV sets are described here, but their effect on the outputs of the lighting board. So in each car a different CV set is activated.

The activation of the CV sets is done by a "pseudo-programming" of CV #8 (with "pseudo-programming" the programmed value is not stored, but only triggers the desired effect).

The sample application of the SECOND address

Activating the appropriate CV sets contained in function decoders and lighting boards (from SW 40.18)

By activating the CV sets in the individual cars, it is thus achieved that the interior lights (and headlights or taillights) for each car can be switched individually by "higher" (from F13) function keys, all from the same locomotive address. It may be necessary to "free" these function keys beforehand, i.e. if they are occupied by a sound project with sound effects, for example, to switch them off.

ATTENTION: CV #8 is read-only; only pseudo-programmable, NOT readable.

Default (automatically activated in lighting boards) CV set "100", replaceable by "102", "103", ... CV set ("100"); with FIRST address and SECOND address effective function mapping if not already default, can be activated by CV #8 = 100 (interior lighting without light effect),

or CV #8 = 101 (interior lighting with fluorescent tube effect)

F0, forw ALL light outputs (F01 - F0_{max}) + Lfor
 F0, rev + Lrev
 F1 F01
 F2 F02
 etc.
 F_{max} F0_{max} (highest function output for interior lighting, usually F04, F08 or F09)
 F10 F010 (only lighting boards LIPLDG.. for large scale)
 F11 All interior lighting (F02 - F0_{max})

NOTE: Default activation "100" only in lighting boards, NOT in Function Decoders.

First Car.

CV set, effective with SECOND address, can be activated by **CV #8 = 102** (without light effect) or **CV #8 = 103** (with fluorescent tube effect)

F13 Lfor resp. Lrev + F01 + F010 (Additional outputs)
 F14 F02 - F0_{max} (All interior lighting)

Second Car.

CV set, effective with SECOND address, can be activated by **CV #8 = 104** (without light effect) or **CV #8 = 105** (with fluorescent tube effect)

F15 Lfor resp. Lrev + F01 + F010 (Additional outputs)
 F16 F02 - F0_{max} (All interior lighting)

Further (3., 4., ..., 8.) Cars:

CV set, effective with SECOND address, can be activated by **CV #8 = 106, 108, ..., 114, 116** (without light effect) or **CV #8 = 107, 109, ..., 115, 117** (fluorescent tube)

F17, F19, ..., F25, F27 Lfor resp. Lrev + F01 + F010 (Additional outputs)
 F18, F20, ..., F26, F28 F02 - F0_{max} (All interior lighting)

modified application: Division of the entire interior lighting into sections of the lighting boards.

CV set, effective with SECOND address, can be activated by **CV #8 = 118** (without light effect) or **CV #8 = 119** (with fluorescent tube effect)

F13 Lfor resp. Lrev + F01 + F010 (Additional outputs)
 F14 F02 - F04 (Interior lighting front part)
 F15 F05 - F06 (Interior lighting middle part)
 F16 F07 - F0_{max} (F08 or F09, Interior lighting rear part)

CV set, effective with SECOND address, can be activated by **CV #8 = 120, 122, 122** (without light effect) or **CV #8 = 121, 123, 125** (fluorescent tube)

F17, F21, F25 Lfor resp. Lrev + F01 + F010 (Additional outputs)
 F18, F22, F26 F02 - F04 (Interior lighting front part)
 F19, F23, F27 F05 - F06 (Interior lighting middle part)
 F20, F24, F28 F07 - F0_{max} (F08 or F09, Interior lighting rear part)

If required, other CV sets will also be provided!

Also see: Chapter: [Calculating the long second address](#)

3.6 Analog Operation

ZIMO decoders (all types) are also suitable for conventional layouts (with model railroad transformers, PWM controllers, etc.), both **analog direct current (DC analog mode)** and **analog alternating current (AC analog mode** for Märklin, also with high voltage pulse for direction reversal).

For analog operation to be possible,

CV #29, Bit 2 = 1

With function decoders, analog mode only affects the function outputs, for which there are setting options as with the Loco decoders.

CV	Denomination	Range	Default	Description
#29	Basic Settings	0 - 63	14 = 0000 1110 includes Bit 2 = 1 (Analog operation enabled)	Bit 0 - Train direction: 0 = normal, 1 = reversed Bit 1 - Number of speed steps: 0 = 14, 1 = 28 Bit 2 - Automatic switchover to analog: 0 = disabled 1 = enabled Bit 3 - RaiCom ("bidirectional communication") 0 = deactivated 1 = activated Bit 5 - Decoder address: 0 = primary address as per CV #1 1 = ext. address as per CV #17 + #18
#13	Functions F1 - F8 in analog mode, also, as "VITRINE MODE"	0 - 255	0	Select the functions that should be ON during analog operation. Bit 0 = 0: F1 OFF in analog mode = 1: ...ON... Bit 1 = 0: F2 OFF in analog mode = 1: ...ON... F3, F4, F5, F6, F7 Bit 7 = 0: F8 OFF in analog mode = 1: ...ON...
#14	Functions F0, F9 - F12 in analog mode, also, as "VITRINE MODE"	0 - 255	67, that is Bit 0, 1, 6 = 1	Select the functions that should be ON during analog operation. Bit 0 = 0: F0 (forward) OFF in analog mode = 1: ...ON... Bit 1 = 0: F0 (reverse) OFF in analog mode = 1: ...ON... Bit 2 = 0: F9 OFF in analog mode = 1: ...ON... F10, F11 Bit 5 = 0: F12 OFF in analog mode = 1: ...ON... Bit 6 = 0: Analog operation with momentum as per CVs #3 + #4; often needed for sound = 1: Analog operation without momentum from CVs #3 + #4; immediate response to track voltage similar to classic analog control.

3.7 "Virtual" motor control, acceleration, braking

Even though function decoders do not have an actual motor output, they can still be programmed with parameters for **"virtual motor control"**, in order to synchronize the actions of the function decoder with the loco decoder, provided the first or second address of the function decoder is identical with the loco decoders. This is especially important during acceleration or deceleration, for example, when activating the direction key without first stopping the train. It makes sense to use the same settings in these CV's as are used in the locomotive decoder.

However, the 28-speed point curve is not available, only the three-point curve, because the relevant CV numbers are used for the second address. For this reason, Bit 4 in CV #29 is also not available. And of course, CV settings that relate to motor feedback are unnecessary.

For many applications though, the motor control CVs are not important in function decoders. Setting CV #3 and #4 to match the CVs of the loco decoder is sufficient.

CV	Denomination	Range	Default	Description
#2	Starting voltage of the three-point curve, if CV #29, bit 4 = 0	1 - 255	1	Internal speed step (1 - 255) for lowest external speed step (i.e. speed step 1) (no matter if 14, 28, or 128 speed steps) = 1: lowest possible starting speed
#5	Maximum speed of the 3-step curve, if CV #29, bit 4 = 0	0 - 255	1 Equals 255	Internal speed step (1 - 255) for highest external speed step (i.e. for external speed step 14, 28 or 128 depending on the speed step system according to CV #29, Bit 1 = 1: corresponds to 255, highest possible final speed
#6	Medium speed	1, 1/2 to 1/2 of the value in CV #5	1 (means: approx. one third of the final speed).	Internal speed step (1 - 255) for average external speed step (i.e. for external speed step 7, 14 resp. 63 depending on the speed step system 14, 28, 128 according to CV #29, bit 1) "1" = default curve (middle speed is one third of the maximum speed, i.e.: if CV #5 = 255, then the curve is the same as if CV #6 = 85). The 3-step curve resulting from CVs #2, #5, #6 is smoothed automatically, therefore no kink.
#3	Acceleration time	0 - 255	2	The content of this CV multiplied by 0.9 gives the time in sec. for the acceleration process from standstill to full speed.
#4	Deceleration time	0 - 255	1	The content of this CV, multiplied by 0.9, results in the time in sec for the deceleration process from full speed to standstill. The actually effective default value see above!
#23	Variation Acceleration	0 - 255	0	For temporary increase of acceleration time according to CV #3; if bit 7 = 1: reduction instead of increase.
#24	Variation Deceleration	0 - 255	0	For temporary increase of deceleration time according to CV #4; if bit 7 = 1: reduction instead of increase.
#121	Exponential Acceleration	0 - 99	0	Acceleration curve according to an approximate exponential function (particularly slow speed increase in the low speed range). Tens digit: Percentage (0 to 90 %) of the speed range for which this curve is to apply.

CV	Denomination	Range	Default	Description
				Ones digit: parameter (0 - 9) for the curvature of the exponential function. Typical initial test values: CV #121 = 11, 23, 25, ...
#122	Exponential Deceleration	0 - 99	0	Braking curve according to an approximate exponential function; the counterpart to CV #121. Tens digit: Percentage (0 to 90 %) of the speed range for which this curve is to apply. Ones digit: Parameter (0 to 9) for the curvature of the exponential function. Often set to a similar value as CV #121.
#123	Adaptive Acceleration and Braking	0 - 99	0	The increase or decrease of the set speed should only take place after a defined approach of the actual speed to the previously specified set speed. CV #123 contains the speed step distance which must be reached. = 0: no adaptive method Tens digit: 0 - 9 for acceleration. (1 = strong effect) ones digit: 0 - 9 for braking = 11: the strongest effect;
#49	Signal-controlled (HLU) Acceleration	0 - 255	0	ZIMO signal-controlled speed influence ("HLU") with track section module MX9, StEin or successors or with signal stop by "asymmetric DCC signal": The content of this CV multiplied by 0.4 gives the time in sec for the acceleration process from standstill to full speed.
#50	Signal-controlled (HLU) Deceleration	0 - 255	0	ZIMO signal-controlled speed influence ("HLU") with track section module MX9, StEin or successors or with signal stop by "asymmetric DCC signal": The content of this CV multiplied by 0.4 gives the time in sec for deceleration from full speed to standstill.
#51 #52 #53 #54 #55	Signal-dependent (HLU) speed limits #52 for "U", #54 for "L", #51, #53, #55 intermediate stages	0 - 255	20 (HU) 40 (U) 70 (UL) 110 (L) 180 (LF)	ZIMO signal-controlled speed influence ("HLU") with track section module MX9, StEin or successor: This determines the actual internal speed step to be applied for each of the 5 speed steps that can be generated by "HLU".
#59	Signal controlled (HLU) Response time	0 - 255	5	ZIMO signal-controlled speed influence ("HLU") with track section module MX9, StEin or successors or with signal stop by "asymmetric DCC signal": Time in tenths of a second in which an acceleration process is initiated after receipt of a higher signal-controlled limit than the previously valid one.

CV	Denomination	Range	Default	Description
#27	Position-dependent Stop (before red signal) by "Asymmetrical DCC - Signal" (ABC)	0, 1, 2, 3	0	Bit 0 = 1: Stopping occurs when right rail (in direction of travel) has higher voltage than left rail. THIS, (i.e. CV #27 = 1) IS THE NORMAL APPLICATION (if the decoder is wired correctly regarding current collectors). Bit 1 = 1: Stopping occurs when left rail (in direction of travel) has higher voltage than right rail. Bit 0 and bit 1 = 1 (so CV #27 = 3): Stopping occurs independent of direction of travel in case of asymmetry.
#29, #124 #112	in these CVs single bits are responsible for the correct reaction to DC and "Märklin" brake sections respectively.	-	-	When using rail polarity dependent DC braking sections CV #29, bit 2 = 0 and CV #124, bit 5 = 1 must be set! For polarity independent DC braking ("Märklin brake sections") CV #29, bit 2 = 0 and CV #124, bit 5 = 1 must also be set and additionally CV # 112, bit 6 = 1!
#124	Shunt key functions: Half speed and Acceleration deactivation NOTE: Extended selection for shunting keys in CVs #155, #156	Bits 0 - 4, 6	0	Selection of a shunting key for ACTIVATION of the HALF SPEED: Bit 4 = 1 (and bit 3 = 0): F3 Bit 3 = 1 (and bit 4 = 0): F7 Selection of a shunting key for DEACTIVATION of ACCELERATION TIMES: Bit 2 = 0 (and Bit 6 = 0): MN key Bit 2 = 1 (and bit 6 = 0): F4 Bit 6 = 1 (bit 2 irrelevant): F3 Range of action of the key (MN, F3 or F4) for DEACTIVATION of ACCELERATION TIMES: Bits 1,0 = 00: no influence on acceleration times = 01: key disables Exponential + Adaptive. = 10: reduces acceleration/deceleration time to % of the values according to CVs #3, #4. = 11: deactivates acceleration/deceleration time completely.
#151	Reduction of the motor control in the Consist. or Motor brake (if address NOT in Consist)	Tens Digit 1 - 9	0	Tens digit 1 - 9 reduces the motor braking to 10 - 90 % of the value according to CV #58. = 0: no motor brake = 1 - 9: If, despite "zero energy supply to the motor (motor PWM zero) the set speed is not reached (speed still too high), is not reached (speed still too high), motor brake is applied slowly (distributed over 1, 2, ... 8 sec until full effect due to motor short circuit via the output stage). The higher the value, the stronger the motor brake is applied. = Tens digit (1-9): Reduction of the motor braking can be set when the Consist key is active. The values 1-9 in the Tens digit of CV #151 reduce the excitation to 10% - 90% of the value set in CV #58.
#155	Selection of a function key for half speed	0 - 19	0	In extension of the settings of CV #124, if the selection there is not sufficient. More info: See manual loco decoders!

CV	Denomination	Range	Default	Description
#156	Selecting a function key for deactivating the acceleration/deceleration times	0 - 19	0	In extension of the settings of CV #124, if the selection there is not sufficient. More info: See manual loco decoders!
#157	Selection of a function key for the MAN function. For cases where the standard MN button on the ZIMO controller is not available.	0 - 19	0	The MAN function (or MAN button on the ZIMO control desk) is a function originally created for ZIMO applications to cancel stops and speed limits by the HLU system of "signal-controlled speed influence". In later software extensions this function was also extended to signal stop by "asymmetric DCC signal" (Lenz ABC).

Function key on the controller	Numeric key on ZIMO Cabs	CV	Function Outputs								
			F06	F05	F04	F03	F02	F01	Rear Light	Front Light	
F0	1 (L) fw	#33	7	6	5	4	3	2	1	0	●
F0	1 (L) re	#34	7	6	5	4	3	2	1	●	0
F1	2	#35	7	6	5	4	3	2	●	1	0
F2	3	#36	7	6	5	4	3	●	2	1	0
F3	4	#37	4	3	2	1	●	0	7	6	5
F4	5	#38	4	3	2	●	1	0	7	6	5
F5	6	#39	4	3	●	2	1	0	7	6	5
F6	7	#40	4	●	3	2	1	0	7	6	5
F7	8	#41	1	0	7	6	5	4	3	2	
F8	9	#42	1	0	7	6	5	4	3	2	
F9	0	#43	1	0	7	6	5	4	3	2	
F10	↑ 1	#44	1	0	7	6	5	4	3	2	
F11	↑ 2	#45	1	0	7	6	5	4	3	2	
F12	↑ 3	#46	1	0	7	6	5	4	3	2	

The black dots in the table above indicate the default settings at the time of delivery, where each function key corresponds to the same numbered function output. Therefore, the following values were written to these CVs by default:

- CV #33 = 1
- CV #34 = 2
- CV #35 = 4
- CV #36 = 8
- CV #37 = 2
- CV #38 = 4
- CV #39 = 8
- CV #40 = 16

EXAMPLE: EXAMPLE for the modification of the function mapping: With the function key F2 (ZIMO key 3) the function output F04 shall be switched in addition to the function output F02. Furthermore, F3 and F4 should NOT be used to switch F03 and F04, BUT outputs F07 and F08 (these could be couplers, for example). New values must therefore be programmed into the relevant configuration variables.

F2	3	#36					7	6	5	●	4	3	●	2	1	0
F3	4	#37			7	6	5	●	4	3	2	1	0			
F4	5	#38			7	6	●	5	4	3	2	1	0			

3.8 Function Mapping (FIRST address) according to NMRA-DCC

CVs #33 to #46 are reserved for the function mapping of the first address. It links a specific function key to a specific function output. It is also possible to control several function outputs with one function key. Each function key is represented by a single CV in the in the table below. The individual bits of a CV represent individual function outputs.

Since function decoders only had a maximum of 8 function outputs (headlights, FA1-FA6) in the past, the "superfluous" bits (see table below) are shifted to the left (according to NMRA rules), so that "low" function outputs (FA0v / r, FA1) can also be controlled by "high" function keys (F3 and higher).

Below: NMRA standard bits (dark gray boxes) and "right shifted" bits (shaded gray):

3.9 Function Mapping (SECOND address) according to NMRA-DCC

The *Function mapping for the Second address* is defined (in the same way as for the first address) with

CVs #69 to #82

The commands of the first and the second address are read separately, and stored according to the respective "function mapping" and the desired function output states.

After power-on (system boot-up, longer track power interruption etc.), the decoder is first waiting for a SECOND ADDRESS command (provided the second address is not 0) and the outputs are set based on this secondary address command. (First-address commands are executed only if changes in the function output states between successive first-address commands occur.) During continued operation the "principle of the most recent change" between first and second address commands applies.

Identical to the first address: NMRA standard bits (dark gray) and "right shifted" bits (shaded gray):

Function key on the controller	Numeric key on ZIMO Cabs	CV	Function Outputs							
			FO6	FO5	FO4	FO3	FO2	FO1	Rear Light	Front Light
F0	1 (L) fw	#69	7	6	5	4	3	2	1	0●
F0	1 (L) re	#70	7	6	5	4	3	2	1●	0
F1	2	#71	7	6	5	4	3	2●	1	0
F2	3	#72	7	6	5	4	3●	2	1	0
F3	4	#73	4	3	2	1●	0	7	6	5
F4	5	#74	4	3	2●	1	0	7	6	5
F5	6	#75	4	3●	2	1	0	7	6	5
F6	7	#76	4●	3	2	1	0	7	6	5
F7	8	#77	1	0	7	6	5	4	3	2
F8	9	#78	1	0	7	6	5	4	3	2
F9	0	#79	1	0	7	6	5	4	3	2
F10	↑ 1	#80	1	0	7	6	5	4	3	2
F11	↑ 2	#81	1	0	7	6	5	4	3	2
F12	↑ 3	#82	1	0	7	6	5	4	3	2

Ende

3.10 "Unilateral light suppression"

This is another feature, asked for by many users, that makes it possible to switch off all light-ing on one side of a locomotive per one function key (usually on the "train side", i.e. where cars are coupled to the locomotive).

CV	Denomination	Range	Default	Description
#107	Light suppression (i.e. front headlights AND additionally defined function output) at cab side 1 (front)	0 - 220	0	The value of this CV is calculated as follows: The number of a function output (FO1 - FO6) x 32 + number of a function key (F1, F2..F28) = Value of CV #107 Function Key: That key which should turn off ALL lights on the cab side 1 (front side) AND Function Output: i.e. taillights on the same side.
#108	Cab side 2 (rear)	0 - 220	0	Same as CV #107 but for other locomotive side.
#109	Additional function output side 1	Bit 0 - 5, 7	0	Bit 0 - 2: 3rd function output (FA1 to FA6) is switched off together with CV #107. Bit 3 - 5: 4th function output (FA1 to FA6) is switched off together with CV #107. Bit 7 = 1: Light suppression active when Consist mode is active.
#110	Additional function output side 2	Bit 0 - 5, 7	0	Same as CV #109 but for reverse direction/driver's cab 2.

3.11 The „Swiss Mapping“

The "Swiss Mapping" is a function mapping that all ZIMO decoders (i.e. not only specifically the function decoders) contain; it was originally created for the requirements of the Swiss lighting systems (hence the name), but has long been used completely independently of them.

The purpose of the "Swiss mapping" is to switch various states of the locomotive lighting with different function keys, i.e. for situations like driving a single locomotive, cars coupled on driver's cab 1, or at the driver's cab 2, push-pull, loco pushing, etc.

The desired lighting states are controlled by **10 CV groups** (non-sound decoders, LIPLDHx, LIPLDNx, MX671 and MX689N18) or **17 CV groups** (sound decoder, remaining function decoder and lighting boards for large scale trains), each consisting of 6 CVs.

In the case of the function decoders: for each of these groups it can be selected (bit 6 in the respective first CV) whether the group should refer to the FIRST or the SECOND address.

The principle of "Swiss Mapping" is that the first CV of each group contains the number (1 to 28) of a function key F1-F28; the other CVs define which function outputs are to be switched on when this key is pressed, each depending on the direction of travel.

More explanation and example: see operating instructions of the "normal" decoders (i.e. those with motor control for locomotives).

CV	Denomination	Range	Default	Description
#430	Swiss Mapping Group 1 "F-Key"	0 - 28, 29 (for F0), 129 - 157	0	The key defined here shall turn on the function outputs listed under A1 (forward or reverse) and A2 (forward or reverse). Bit 6 = Swiss Mapping group applies to secondary address. Bit 7 = 1: Inverts the F-key function.
#431	Swiss Mapping Group 1 "M-Key" or Special high-beam setting	Bit 0 - 6: 0 - 28, 29 (for F0) and Bit 7 or 255	0	The "normal function mapping" (according to CVs #33-#46) for the "M-key" defined here will be deactivated (that is the assigned outputs) when the "F-key" is switched on. Bit 7 = 1: the outputs listed under A1 and A2 should only switch ON if the F and M key are ON. Bit 6 = 1: The M-key outputs shall not be turned OFF if the F-key is ON and driving forward. (From SW-Vers. 35) Bit 5 = 5: The M-key outputs shall not be turned OFF if the F-key is ON and driving backwards. (From SW-Vers. 35) = 157: is an often-used value for this CV, because F0 (= 29) is usually selected as the "M-key" with Bit 7 = 1. F0 then acts as a general ON/OFF key. = 255 (Special high-beam setting!): the Fu-Outputs defined in the following four CVs are switched to full intensity, if they are controlled via the "normal function mapping", and dimmed with CV #60 or a dimming group; this function is used, for example, to switch the headlights of a Swiss locomotive to high-beam, without switching the white taillight to high-beam. Depending on CV #399 setting: High beam is only switched on if the speed is higher than the value given in this CV.
#432	Swiss Mapping Group 1 "A1" forward	Bits 0 - 3: 1 - 12 14 (F00f) 15 (F00r) Bits 5 - 7: 0 - 7	0	Bits 0 - 3: Function output to be switched ON in forward direction provided that both the "F" and "M" keys are ON (if Bit 7 for the "M" key of this group is 1, otherwise "F" key ON is sufficient). Bits 7, 6, 5 (7 possible values or zero): Number of the applicable dimming CV. For example: Bit 5 = 1 means dimming according to CV #508 etc.
#433	Swiss Mapping Group 1 "A2" forward	Bits 0 - 3: 1 - 12 14 (F00f) 15 (F00r) Bits 5 - 7: 0 - 7	0	Bits 0 - 3: Additional function output to be switched ON in forward direction provided that both the "F" and "M" keys are ON (if Bit 7 for the "M" key of this group is 1, otherwise "F" key ON is sufficient). Bits 7, 6, 5 (7 possible values or zero): Number of the applicable dimming CV. For example: Bit 5 = 1 means dimming according to CV #508 etc.
#434	Swiss Mapping Group 1 "A1" reverse	Bits 0 - 3: 1 - 12 14 (F00v) 15 (F00r) Bits 5 - 7:	0	Bits 0 - 3: Additional function output to be switched ON in reverse direction provided that both the "F" and "M" keys are ON (if Bit 7 for the "M" key of this group is 1, otherwise "F" key ON is sufficient). Bits 7, 6, 5 (7 possible values or zero): Number of the applicable dimming CV. For example: Bit 5 = 1 means dimming according to CV #508 etc.

		0 - 7		
#435	Swiss Mapping Group 1 "A2" reverse	Bits 0 - 3: 1 - 12 14 (FA0v) 15 (FA0r) Bits 5 - 7: 0 - 7	0	Bits 0 - 3: Additional function output to be switched ON in reverse direction provided that both the "F" and "M" keys are ON (if Bit 7 for the "M" key of this group is 1, otherwise "F" key ON is sufficient). Bits 7, 6, 5 (7 possible values or zero): Number of the applicable dimming CV. For example: Bit 5 = 1 means dimming according to CV #508 etc.
#436 - #441	... - Group. 2	...	0	All 6 CVs of Group 2 are defined the same way as the 6 CVs in group 1.
#442 - 447	... - Group. 3	...	0	All 6 CVs of the following groups are defined the same way as the 6 CVs in group 1.
#448 - #453	... - Group. 4	...	0	...
#454 - #459	... - Group. 5	...	0	...
#460 - #465	... - Group. 6	...	0	...
#466 - #471	... - Group. 7	...	0	...
#472 - #477	... - Group. 8	...	0	...
#478 - #483	... - Group. 9	...	0	...
#484 - #489	... - Group 10	...	0	...
#490 - #495	... - Group 11	...	0	...
#496 - #501	... - Group 12	...	0	...
#502 - #507	... - Group 13	...	0	...
#800 - #805	... - Group 14	...	0	... Groups 14 - 17 from SW version 40.4
#806 - #811	... - Group 15	...	0	...
#812 - #817	... - Group 16	...	0	...
#818 - #823	... - Group 17	...	0	...
#508 #509 #510 #511 #512	Dimming values for "Swiss Mapping"	(0-31)*8 (only Bits 7 - 3 are used)	0	One of these five CVs, i.e. the five dimming values contained therein, can be linked to in each of the group CVs (e.g. #432, #433, #434, #435). This means that the function outputs to be switched on are to be dimmed accordingly. Can be used with function outputs FA0 to FA13. Bit 0 = 1: suppresses the light effect Bit 1 = 1: Blinking effect Bit 2 = 1: Inverse blinking effect

3.12 Dimming and fading, direction bit on outputs

Dimming reduces the brightness of the lights by pulse width modulation. This is often necessary because small loads (such as 18 V lamps) cannot be operated with the full rail voltage (sometimes up to 24 V). It also serves to reduce the brightness of the lights. The best solution in such cases is to connect the positive pole of such devices to the low voltage supply of the decoder (see chapter 2 "Technical data, connection diagrams"). Such low-voltage outputs are fully stabilized and the voltage will not fluctuate with changes in track voltage.

Alternatively, or in addition to this (the dimming effect is not limited to devices connected to full track power but also works with low voltage), the PWM (pulse width modulation) voltage reduction is also available with **CV #60**,

which defines the PWM duty cycle. Of course, this kind of voltage reduction is also interesting because it is easy to change at any time.

LEDs, on the other hand, require a series resistor; if, however, the resistor is designed to operate at 5 V, the PWM dimming is also sufficient at a track voltage of 25 V (in this case the setting would be CV #60 = 50, so a reduction by one fifth). CV #60 generally affects all function outputs. The dimming function can be restricted to specific function outputs using the following dim mask CVs.

CV	Denomination	Range	Default	Description
#60	Dimming of the function outputs = Voltage reduction of the function outputs via PWM. Generally valid for all function outputs.	0 - 255	0	Reduction of function output with PWM (pulse-width modulation). Useful for example for headlight dimming. <u>Example values:</u> CV #60 = 0 or 255: full voltage CV #60 = 170: 2/3 of full voltage. CV #60 = 204: 80% of full voltage.
#114	Dim Mask 1 = Excludes certain function outputs from dimming per CV #60. For higher function outputs go to CV #152.	Bits 0 - 7	0	Enter function outputs that are not to be dimmed as per CV #60. These outputs will use the full voltage available from the decoder's positive pin. Bit 0 - front headlight, Bit 1 - rear headlight, Bit 2 - function output F01, Bit 3 - F02, Bit 4 - function output F03, Bit 5 - F04 Bit 6 - function output F05, Bit 7 - F06 Bit value = 0: Output will be dimmed to the value defined in CV #60. Bit value = 1: Output will not be dimmed.
#152	Dim Mask 2 Continuation of CV #114 and F03, F04 as Directional outputs	Bits 0 - 5 and Bit 6, Bit 7	0	... Continuation of CV #114. Bit 0 - function output F07, Bit 1 - function output F08, Bit 2 - function output F09, Bit 3 - function output F010, Bit 4 - function output F011, Bit 5 - function output F012. Bit 6 = 0: „normal“ = 1: "Direction bit" at F03 and F04 that is, F03 is switched on when driving in reverse, F04 is switched on when driving forward (Normal mapping of F03 and F04 is invalid when this Bit is set). Bit 7 = 1: "Direction bit" for F09 when moving forward

Low/high beam with the help of the low beam mask

ATTENTION: Bulbs with voltage ratings as low as 12 V can be dimmed with this PWM dimming function without damage even if track voltages are considerably higher; but **not** bulbs rated below that such as 5 V or 1.2 V bulbs. These must be connected to one of the decoder's low voltage supply pins instead of a normal

One of the two function keys F6 (CV #119) or F7 (CV #120) can be defined as a low beam key. Specific function outputs can be dimmed when the output turned ON or OFF (inverted action with Bit 7).

CV	Denomination	Range	Default	Description
#119	Low beam mask for F6 - Output assignment for (example) low/high beam headlights ATTENTION: Certain settings in CV #154 (Special output configurations) change the meaning of CVs #119 and #120 and therefore will no longer work as a low-beam mask.	Bits 0 - 7	0	Selected function outputs will dim with F6 key, according to the dim value in CV #60. Typical application: Low/high beam Bit 0 - front headlight, Bit 1 - rear headlight, Bit 2 - function output F01, Bit 3 - function output F02, Bit 4 - function output F03, Bit 5 - function output F04. Bit 6 - function output F05 Bit value = 0: Output will not be dimmed, Bit value = 1: Output will be dimmed with F6 to value defined in CV #60. Bit 7 = 0: normal action of F6. = 1: inverted action of F6. <u>EXAMPLE:</u> CV #119 = 131: Function key F6 toggles headlights between low and high beam.
#120	Low beam mask for F7	Bits 0 - 7		Same as CV #119 but with F7 as low beam key.

A "second dim value" with the help of the uncoupler- CV

If more function outputs need to be dimmed than CV #60 allows or if some function outputs require a different voltage and the uncoupler function is not needed on the same vehicle then

CV #115

can be used for an alternative low voltage supply. The respective function outputs must be defined as "uncoupler output" in the corresponding

CVs #125 - #132, #159 and #160

(see "Effects for function outputs ("new level" as of SW version 40.19).

CV	Denomination	Range	Default	Description
#115	Uncoupler control or Second dim value	0 - 99	0	Only active as uncoupler if "uncoupler" function is selected (value 48) in CV #125 - #132, #159 or #160: Tens digit = 0: used for dimming. Ones digit (0 to 9): PWM - voltage reduction (0 to 90%)
#127 - #132 #159 #160	Effects on F01, F02, F03, F04, F05, F06 F07, F08		0 0	= 48 when used as dimming value #127 → F01 #128 → F02 #129 → F03 #130 → F04 #131 → F05 #132 → F06 #159 → F07 #160 → F08

3.13 The blink effect

Blinking is actually a lighting effect just like all the others that are summarized in the CVs starting with #125; but for historical reasons are listed in their own CVs #117 and #118.

CV	Denomination	Range	Default	Description
#117	blinking functions Outputs are assigned in CV #118. blinking mask	0 - 99	0	Duty cycle for flasher function: Tens digit = OFF time Ones digit = ON time (0 = 100msec, 1 = 200msec.....9 = 1 sec) <u>Example:</u> CV #117 = 55: Flashes evenly at 1 a second interval.
#118	Blinking mask - Defines which outputs operate as flashers as programmed in CV #117	Bits 0 - 7	0	Selected function outputs will blink when turned ON. Bit 0 - front headlights Bit 1 - rear headlights Bit 2 - function output F01, Bit 3 - ...F02 Bit 4 - ...F03, Bit 5 - function output F04. Bit value = 0: No flasher Bit value = 1: Output flashes when turned ON. Bit 6 = 1: F02 flashes inverse! Bit 7 = 1: F04 flashes inverse! (for alternate flashing, i.e. wig-wag) <u>EXAMPLE:</u> CV #118 = 12: F01 and F02 are defined as flashers. CV #118 = 168: Alternate flashing of F02 and F04

3.14 F1 Pulse Chains (Only for old LGB products)

#112	Special ZIMO configuration Bits	0 - 255	2	Bit 3 = 0: 12-Function mode = 1: 8-Function mode Bit 4 = 0: Pulse chain recognition OFF = 1: P Pulse chain recognition ON (use with old LGB systems) ... Bit 7 = 0: no pulse chain generation = 1: Generates pulse chain commands for LGB sound modules.
------	---------------------------------	---------	---	--

3.15 Effects for function outputs ("new level" as of SW version 40.19) (American and other light effects, smoke generators, couplers, etc.)

A total of 12 function outputs can be assigned "effects"; this is done with

CVs ("Main Level") #125, #126, #127 #132, #159, #160, #195, #196
und ("New Level") #850, #851, #852 # 857, #858, #859, #860, #861
for Front Light, Rear Light, FA1, FA2, FA3, FA4, FA5, FA6, FA7, FA8, FA9, FA10

The values programmed into the **effect CVs #125 ... #196** ("main level") consist of the actual **6-bit** effect code (bits 7 - 2) and the **2-bit** direction code (bits 0,1).

Bits 1,0 = 00: bidirectional (active in both directions)

= 01: active in forward direction only (+ 1)
= 10: active in reverse direction only (+ 2)

Bits 7 ... 2 = 000000xx	No effect, except for	direction = 00, 1, 2 (bidirectional, forward, reverse)	
= 000001xx	Mars light	+ direction = 4, 5, 6 (bidirectional, forward, reverse)	
= 000010xx	Random flicker	+ direction = 8, 9, 10 (ditto, ditto, ditto)	
= 000011xx	Flashing headlight	+ direction = 12, 13, 14 ...	
= 000100xx	Single pulse strobe	+ direction = 16, 17, 18	
= 000101xx	Double pulse strobe	+ direction = 20, 21, 22	
= 000110xx	Rotary beacon	+ direction = 24, 25, 26	
= 000111xx	Gyalite	+ direction = 28, 29, 30	
= 001000xx	Ditch light type 1, right	+ direction = 32, 33, 34	
= 001001xx	Ditch light type 1, left	+ direction = 36, 37, 38	
= 001010xx	Ditch light type 2, right	+ direction = 40, 41, 42	
= 001011xx	Ditch light type 2, left.	+ direction = 44, 45, 46	
= 001100xx	Uncoupler as defined in CV #115 automatic disengagement in CV #116		= 48, 49, 50
= 001101xx	"Soft start" = slow power-up of function output		= 52, 53, 54
= 001110xx	Automatic stoplights for street cars, stoplight-off delay, see CV #63.		= 56, 57, 58
= 001111xx	Function output turns itself off at speed >0 (i.e. turns off cab light when driving).		= 60, 61, 62
= 010000xx	Function output turns itself off after 5 minutes (i.e. to protect smoke generators form overheating).		= 64, 65, 66
= 010001xx	As above, but after 10 minutes		= 68, 69, 70
= 010010xx	Speed or load dependent smoke generation for steam engines as per CVs #137 - #139 (i.e. pre-heating at standstill, heavy smoke at high speed or high load). Smoke turns itself off as per CV #353; function key must be pressed to reactivate smoke.		= 72, 73, 74
= 010011xx	Protection circuit for servos by means of relay which is switched OFF, if voltage supply for generation of control signals too small.		= 76
= 010100xx	Driving state-dependent smoke generation for diesel engines as per CVs #137 - #139 (i.e. pre-heating at standstill, heavy smoke during motor start-up sound and acceleration).		= 80, 81, 82
= 010110xx	Slow dimming up & slow dimming down of a function output; useful for various lighting effects or motor-driven devices (for example, for fans or snowblower wheels). Setting of the Dimming up and down time in CVs #190, #191! <i>(from SW-Version 33.10 for Sound-Decoder)</i> <i>(from SW-Version 32.1 for non-Sound)</i>		= 88, 89, 90
= 010111xx	Fluorescent tube flicker effect	<i>(from SW-Version 36.7)</i>	= 92, 93, 94
= 011000xx	Brake spark during heavy braking	<i>(from SW-Version 37.0)</i>	= 96, 97, 98

The effect CVs enable **direction-dependent function outputs** even without effect (i.e. effect code 000000)

e.g.: CV #127 = 1, CV #128 = 2, CV #35 = 12 (F01, F02 direction dependent switchable with function key F1).

The values programmed into the **effect CVs #850 - #861** ("new level") consist only of the **8-bit effect code (bits 7 - 0)**, the direction is taken from CVs #126 ...

Effekt-Code (Bits 7 - 0) = 0	no Effect
1	Function output is not always switched on when the function is activated, but randomly (with approx. 2/3 probability); new probability calculation each time the function is switched on (i.e. different areas of the carriage are always illuminated).
2	Function output is switched on if assigned function is switched on, and speed = 0 (loco is not moving).
3	Function output is switched on when speed = 0 (locomotive does not move), independent of any function.
4	Function output is switched on if assigned function is switched on, and speed > 0 (loco is moving).
5	Function output is switched on when speed > 0 (loco is running), independent of any function.
6	Function output is switched on when direction of travel is Forward.
7	Function output is switched on when direction of travel is Reversed.
8	Only useful if at least two function outputs are assigned to the same function and have effect code 8; these function outputs are not switched on immediately when the (jointly) assigned function is switched on, but at time intervals of 0.6 sec. each. In this way, for example, the front lights of an electric or diesel locomotive can be switched with one key-stroke.
9	Function output is switched on with a delay after the assigned function.
10	Function output is switched off if speed > CV #399.
11	Function output is switched off if speed <= CV #399.
12	Function output is switched on when the shunt key is switched on.
13	Function output is switched off when the shunt key is switched on.

Logical order of the "new level", i.e. the effects according to CV #850 - #861, i.e. order of processing from the functions and driving data to the function outputs:

Function Mapping >>> Effects of the "New Level" (CVs # 850, ...) >>> Effects of the „Main level“

3.16 Configuration of Electric Uncouplers

„System KROIS“ and „System ROCO“

When one or two of the function outputs **F01 - F06** (but not F07 or F08) are assigned to the uncoupler function (CV #127 for F01 etc.), the control of the couplers as well as the entire uncoupling process is defined by the settings in

CV #115 and CV #116.

These CVs limit the pull-in time (to prevent overheating), define a hold-in voltage if required (i.e. System "Roco") as well as the automated coupler unloading and train disengagement.

It is recommended to use the following settings for the **Krois system: CV #115 = 60, 70 or 80**; these settings will limit the pull-in voltage (full track power) to 2, 3 or 4 seconds respectively. A hold-in voltage is not required for the Krois coupler and the ones digit can therefore remain at "0".

CV	Denomination	Range	Default	Description
#115	Uncoupler control "Pull-in" time and "hold" voltage or use CV #115 for an alternative second dim value (by setting Tens digit to "0") Ones digit from 0 to 90%.	0 - 99	0	Uncoupler function is only active if "uncoupler" is selected (value 48) in one of the CV's #127 - #132, #159, 160: Tens digit (0 - 9): Time in seconds the coupler receives full voltage (pull-in time): Value: 0 1 2 3 4 5 6 7 8 9 seconds: 0 0,1 0,2 0,4 0,8 1 2 3 4 5 Ones digit (0 to 9): hold-in power in percent of track voltage, 0 - 90%. Applied after the pull-in time elapsed (necessary for ROCO coupler, not needed for KROIS coupler).

3.17 SUSI-Interface and Logic Level Outputs

All decoders described in this manual (except for the MX681) have outputs that can either be used as a SUSI interface, as logic level outputs or for servo control. These outputs are available at solder pads or on the decoder plug (MTC or PluX), see the various decoder drawings starting on page 3.

These outputs are active by default as SUSI interface. They can be switched for the alternative applications with CV #124 (Bit 7) or CVs #181 and #182 (see next chapter "Servo configuration").

CV	Denomination	Range	Default	Description
#124	Shunting key functions: Changing SUSI outputs	Bits 0 - 4, 6	0	Bits 0 - 4, 6: Shunting key selection and HALF-SPEED ACTIVATION Bit 5 = 1: "DC holding sections". Bit 7 = 0: SUSI active instead of normal functions = 1: Normal function outputs instead of SUSI

3.18 Servo Configuration

CV	Denomination	Range	Default	Description
#161	Servo outputs: Protocol	0 - 3 0 NOTE: CV #161 <u>must</u> be set to "2" for Smart Servo RC-1!	0	Bit 0 = 0: Servo protocol with positive pulses. = 1: Servo protocol with negative pulses. Bit 1 = 0: Control wire only active during movement = 1: ... always active (consumes power, vibrates at times but holds position even under mechanical load) - this setting is also required for SmartServo RC-1 (with memory wire)! Bit 2 = 0: Moves to center position, if defined for two-key operation (see CV #181/#182), when both function keys are OFF. = 1: Servo runs only if function keys are pressed when in two-key operating mode (see CV #181/#182). Bit 6 = 0: Servo1 for first address = 1: Servo1 for secondary address Bit 7 = 0: Servo2 for first address = 1: Servo2 for secondary address
#162	Servo 1 Left stop	0 - 255	49 = 1 ms Servopuls	Servo's left stop position. "Left" may become the right stop, depending on values used.
#163	Servo 1 Right stop	0 - 255	205	Defines the servo's right stop position.
#164	Servo 1 Center position	0 - 255	127	Defines a center position, if three positions are used.
#165	Servo 1 Rotating speed	0 - 255	30 = 3 sec	Rotating speed; Time between defined end stops in tenths of a second (total range of 25 sec, default 3 sec.).
#166 - #169	As above but for Servo 2			
#181 #182	Servo 1 Servo 2 Function assignment	0 - 28 90 - 93 101-114	0 0 0 0	= 0: Servo not in operation = 1: Single-key operation with F1 = 2: Single-key operation with F2 and so on to = 28: Single-key operation with F28 = 90: Servo action depends on loco direction: forward = turns left; reverse = turns right = 91: Servo action depends on loco stop and direction: turns right when stopped and direction is forward, otherwise turns left. = 92: Servo action depends on loco stop and direction: turns right when stopped and direction is reverse, otherwise turns left. = 93: Servo action depends on loco movement: turns right when loco stopped, left when loco moving; direction makes no difference. = 101: Two-key operation F1 + F2 = 102: Two-key operation F2 + F3 etc. = 111: Two-key operation F11 + F12 = 112: Two-key operation F3 + F6 = 113: Two-key operation F4 + F7 = 114: Two-key operation F5 + F8 (Two-key operation according to CV #161, Bit 2)

Connecting servos to decoder:

consult the loco decoder manual!

3.19 The Low Voltage for Function Outputs (Only Function-Decoders MX675, MX676)

CV	Denomination	Range	Default	Description
#264	Setting the Output "Low voltage" of the decoders MX675V.., MX676V..	Bit 0 - 7	0	Dezimal 0: 1.5 V " 1: 3 V " 2: 5 V " 3: 6.5 V " 4: 12 V " 5: 14 V " 6: 16 V " 7: 17 V

Optionally, the low voltage can also be set by solder bridges; see connection diagrams of the MX675V, MX676V decoders in the chapter "Technical data, connection diagrams". The use of solder bridges has the advantage over the use of the CV that the setting is not lost even in case of a hard reset; it is therefore preferred above all by vehicle manufacturers who install the function decoder at the factory and connect specified consumers (e.g. low voltage lamps or servos).

It is convenient and recommended to use only one of the two possibilities (CV #264 or solder bridges) to set the low voltage.

But it is also possible to combine the two methods: if the value in CV #264 is read binary (so for example 3 = 0000 0011) the "1" are equal to connected solder bridges (so in case of 3 like X1 and X2). The low voltage results from the OR-connection of the solder bridges (X1, X2, X3) and the bits 0, 1, 2 of CV #264. So, the combination always results in a higher voltage, for example CV #264 = 3 AND solder bridge X3 results in 17 V.

4 CV - overview; CVs in numerical order

This overview summarizes all CVs in numerical order; mostly identically adopted from the descriptions in the preceding (context-related) chapters of this manual, in some cases shortened. In this CV overview there are **NO** notes to SW versions (from SW version ...; see context-related chapters).

Red column on the left: Reference to contextual chapter where the relevant CV description can be found. Chapter numbers clickable.

	CV	Denomination	Range	Default	Description	
	3.4	#1	First (short) Address	DCC: 1 - 127 MM: 1 - 255	3	The "short" first address (DCC, MM). In the case of DCC: The address in CV #1 is only valid if CV #29, Bit 5 = 0. If CV #29 Bit 5 = 1, the long address in CV #17 + #18 is used.
	3.7	#2	Start-up voltage V _{start} with 3-step curve if CV #29, Bit 4 = 0	1 - 255	1	Internal speed step (1 - 255) applied as lowest external speed step (= speed step 1) (applies to 14, 28, or 128 speed step modes) = 1: lowest possible speed
	3.7	#3	Acceleration rate	0 - 255	(2)	The value multiplied by 0.9 equals acceleration time in seconds from stop to full speed. The effective default value for sound decoders is usually not the value given here, but is determined by the loaded sound project.
	3.7	#4	Deceleration rate	0 - 255	(1)	The value multiplied by 0.9 equals deceleration time in seconds from full speed to a complete stop. The effective default value for sound decoders is usually not the value given here, but is determined by the loaded sound project.
	3.7	#5	Maximum speed V _{high} with 3-step curve if CV #29, Bit 4 = 0	0 - 255	0, 1 Equals 255	Internal speed step (1 - 255) applied as highest external speed step (14, 25 or 128, depending on the speed step mode selected in CV # 29, Bit 1) = 1 (same as 0 and 255): fastest speed possible.
	3.7	#6	Medium Speed V _{mid}	1, ¼ to ½ of the value in CV #5	1 (= approx. 1/3 of top speed)	Internal speed step (1 - 255) applied as medium external speed step (that is, speed step 7, 14 or 63 depending on the speed step mode selected in CV #29, Bit 1) "1" = default curve (Medium speed is set to one third of top speed, i.e., if CV #5 = 255 the curve is the same as if CV #6 would be programmed to 85) The speed curve resulting from CV #2, #5 and #6 is automatically smoothed out to prevent kinks.
	3.3	#7	Manufacturer Version No. (SW-Version) Also see CV #65 for Sub-Version Number and	Read only	-	Reading this CV gives the version number of the software (firmware) currently loaded in the decoder. CV #7 = the number of the main version CV #65 = number of the subversion With the help of "Pseudo-programming" it also helps to program decoders with DCC systems of limited range: Ones digit = 1: Subsequent programming value + 100

	CV	Denomination	Range	Default	Description	
		special procedures for programming with "Lokmaus-2" and other "low level" systems			= 2: ... + 200 Tens digit = 1: Subsequent CV number + 100 = 2: ... + 200 etc. = 9: ... + 900 Hundreds digit = 0: Revaluation applies only once = 1: Revaluation applies until power-off	
	3.3 3.5	#8	Manufacturer ID and HARD RESET by CV #8 = 8 or CV #8 = 0 or ACTIVATION of special CV sets	Read only 145 is always read out as ZIMO identifier For pseudo programming see "Description" column on the right.	145 (= ZIMO)	Reading out this CV always result in "145" ("10010001"), the number issued for ZIMO by the NMRA. This CV is also used to reset the decoder by Pseudo-Programming. Pseudo-Programming means that the entered value is not really stored, but rather used to start a defined action. CV #8 = "3" → 21MTC decoder F03, F04 logic level CV #8 = "4" → 21MTC decoder F03, F04 amplified CV #8 = "5" → 21MTC decoder F05, F06 logic level CV #8 = "6" → 21MTC decoder F05, F06 amplified CV #8 = "8" → HARD RESET (NMRA standard); all CVs reset to the last active CV set, or the default values listed in this CV table if no such set was active. CV #8 = "0" → NOT recommended (service purposes only), Default values of the CV table
	3.6	#13	Alternate Mode Function Status F1- F8	0 - 255	0	Select the functions that should be ON during analog operation. Bit 0 = 0: F1 OFF in analog mode = 1: ...ON... Bit 1 = 0: F2 OFF in analog mode = 1: ...ON... F3, F4, F5, F6, F7 Bit 7 = 0: F8 OFF in analog mode = 1: ...ON...
	3.6	#14	Alternate Mode Function. Status F0, F9-F12	0 - 255	67	Select the functions that should be ON during analog operation. Bit 0 = 0: F0 (forward) OFF in analog mode = 1: ...ON... Bit 1 = 0: F0 (reverse) OFF in analog mode = 1: ...ON... Bit 2 = 0: F9 OFF in analog mode = 1: ...ON... Bit 3, Bit 4: F10, F11 Bit 5 = 0: F12 OFF in analog mode = 1: ...ON... Bit 6 = 0: Analog operation with momentum as per CVs #3 + #4; often needed for sound = 1: Analog operation without momentum from CVs #3 + #4; immediate response to track voltage similar to classic analog control.
	3.4	#17 #18	Extended (long) address	128 - 10239	192 128	The long DCC address applies to addresses >127. It is only active if CV #29 Bit 5 = 1.
	3.4	#19	Consist address	0, 1 - 127, 129 - 255 (+ 1 - 127 mit inv. Richtung)	0	A common consist address for 2 or more engines can be entered in this CV to each loco of the same consist. If CV #19 > 0: Speed and direction is governed by this consist address (not the individual address in CV #1 or #17 + #18); functions are controlled by either the consist or individual address, see CVs #21 + #22. Bit 7 = 1: Direction of travel of this locomotive inverted

	CV	Denomination	Range	Default	Description
3.4	#20	Extended Consist address	0 - 102	0	"Long" consist address: the value set in CV #20 is multiplied by 100 and added to the value in CV #19, which then gives the consist address. So e.g. CV #20 = 12, CV #19 = 34 is addr. 1234; CV #20 = 100, CV #19 = 00 is addr. 10000 Bit 7 = 1 activates Railcom on second address
3.4	#21	Consist addr active for F1 - F8	0 - 255	0	Functions defined here will be controlled by the consist address. Bit 0 = 0: F1 controlled by individual address = 1: by consist address Bit 1 = 0: F2 controlled by individual address = 1: by consist address F3, F4, F5, F6, F7 Bit 7 = 0: F8 controlled by individual address = 1: by consist address
3.4	#22	Functions F0 forward, reverse, F9 - F27 in Consist and Activation Auto-Consist	0 - 255	0	Select whether headlights and/or functions F9 - F12 are controlled via consist address or individual address. Bit 0 = 0: F0 (forw.) controlled by individual address = 1: by consist address Bit 1 = 0: F0 (rev.) controlled by individual address = 1: by consist address Bit 2 = 0: F9 controlled by individual address = 1: by consist address Bit 3 = 0: F10 controlled by individual address = 1: by consist address Bit 4 = 0: F11 controlled by individual address = 1: by consist address Bit 5 = 0: F12 controlled by individual address = by consist address Bit 6 = 1: Auto-Consist: The system automatically switches between individual and consist address if one of the two addresses has speed 0 and the other address has speed greater than 0. Bit 7 = 1: F13 - F27 (all)by consist address
3.7	#23	Acceleration Adjustment	0 - 255	0	To temporarily increases the acceleration rate to a new load or when used in a consist. Bit 0-6: entered value increases or decreases acceleration time in CV #3. Bit 7 = 0: adds above value to CV #3. = 1: subtracts above value from CV #3.
3.7	#24	Deceleration Adjustment	0 - 255	0	As above, but for deceleration and therefore CV #4.
3.1 3.7	#27	„BRAKE MODES“: Position-dependent stopping ("before the red signal") or slow driving by means of "Asymmetric DCC - Signal" (Lenz ABC) or		0 = ABC not active, HLU active (!), other braking sections not active.	Bit 0 and bit 1 = 0: ABC is NOT active, no stopping. Bit 0 = 1: ABC stop occurs when right rail (in direction of travel) has higher voltage than left rail. This (CV #27 = 1) is the usual ABC application. Bit 1 = 1: ABC stop occurs when left rail (in direction of travel) has higher voltage than right rail. If Bit 0 or Bit 1 = 1 (only one, not both): Stopping is direction-dependent, i.e. only in the direction of travel towards the signal, passage in the opposite direction. Bit 0 and bit 1 = 1: Stopping is independent of direction.

	CV	Denomination	Range	Default	Description
		"ZIMO HLU" or DC brake sections and "Märklin brake section"			
3.1	#28	Bi-Directional Communication Configuration	0 - 3		Bit 0 - RailCom Channel 1 (Broadcast) 0 = OFF 1 = ON Bit 1 - RailCom Channel 2 (Data) 0 = OFF 1 = ON
3.1 3.4 3.6 3.7	#29	Basic Settings	0 - 63	14 = 0000 1110 also Bit 3 = 1 („RailCom“ eingeschaltet), und Bits 1,2 = 1 (28 oder 128 Fahrstufen, und autom. Analogbetr.)	Bit 0 - Train direction: 0 = normal, 1 = reversed Bit 1 - Number of speed steps: 0 = 14, 1 = 28/128 Bit 2 - Automatic switch to analog mode 0 = disabled 1 = enabled Bit 3 - RailCom („bidirectional communication“) 0 = deactivated 1 = activated Bit 4 - Individual speed table: 0 = off, CV #2, #5 and #6 are active. 1 = on, according to CVs #67 - #94 Bit 5 - Decoder address selection: 0 = short address as per CV #1 1 = long address as per CV #17 + #18
3.8	#33	NMRA Function mapping F0	0 - 255	1	Function mapping for F0 forward for first address
3.8	#34	NMRA Function mapping F0	0 - 255	2	Function mapping for F0 reverse for first address
3.8	#35 - #46	Function mapping F1 - F12	0 - 255	4, 8, 2, 4, 8, ...	Function mapping for F1 - F12 for first address
3.7	#49	Signal-controlled (HLU, ABC) acceleration	0 - 255	0	Entered value multiplied by 0.4 equals acceleration time in seconds from stop to full speed when: "ZIMO signal-controlled speed influence" (HLU) with ZIMO MX9 track section module, StEin, or successor or "Asymmetrical DCC signal" method (Lenz ABC) is employed
3.7	#50	Signal controlled (HLU, ABC) deceleration	0 - 255	0	Entered value multiplied by 0.4 equals deceleration time in seconds from full speed to complete stop when: "ZIMO signal-controlled speed influence" (HLU) with ZIMO MX9 track section module, StEin, or successor or "Asymmetrical DCC signal" method (Lenz ABC) is employed
3.7	#51 #52 #53 #54 #55	Signal controlled (HLU) speed limits #52 for "U", #54 for "L", #51, #53, #55 for intermediate steps	0 - 255	20 (HU) 40 (U) 70 (UL) 110 (L) 180 (LF)	ZIMO "signal controlled speed influence" method (HLU) using MX9, StEin or successor: Defines the internal speed steps for each of the 5 speed limits generated via HLU.

	CV	Denomination	Range	Default	Description
3.7	#58	Control influence From SW-Version 5.00	0 - 255	255	Extent for the balancing force by the EMF load balancing control at lowest speed. EXAMPLE VALUES: CV #58 = 0: no control (like uncontrolled decoder), CV #58 = 150: medium strong regulation, CV #58 = 255: as strong regulation as possible.
3.7	#59	Signal controlled (HLU) delay	0 - 255	5	ZIMO signal-controlled speed influence ("HLU") with track section module MX9, StEin or successors or with signal stop by "asymmetric DCC signal": Time in tenths of a second in which an acceleration process is initiated after receipt of a higher signal-controlled limit than the previously valid one.
3.12	#60	Reduced function output voltage (Dimming). Affects all function outputs.	0 - 255	0	Reduction of function output with PWM (pulse-width modulation). Useful for example for headlight dimming. EXAMPLE VALUES: CV #60 = 0 or 255: full voltage CV #60 = 170: 2/3 of full voltage. CV #60 = 204: 80% of full voltage.
3.15	#62	Modify light effects	0-9	0	Changing the minimum dim value (0 - 90%)
3.15	#63	Light effects modifications or Stop light OFF delay	0 - 99 0 - 255	51	Tens digit: sets cycle time (0 - 9, default 5), or start-up time during soft start with 001101 (0 - 0,9s) Ones digit: OFF delay time (range: 0 - 25 sec.). For stop light OFF delay (001110xx in CV #125, #126 or #127): Time in tenths of a second the stop lights remain ON after the street car comes to a full stop.
3.5	#64	Short SECOND address	1 - 127	0	The "short" SECOND address; this is active when bit 5 in CV #112 is set to 0.
3.3	#65	SW subversion number See also CV #7 Version number	Read-only	-	This CV indicates a possible sub-version number of the main version noted in CV #7. The entire SW version number is thus composed of CV #7 and #65 (i.e.: 28.15).
3.5	#67 + #68	Long SECOND ADDRESS	128 - 10239	0	The "long" second address; it is active when CV #112, Bit 5 = 1. NOTE: In contrast to the "first long address", the cab cannot calculate the proper CV values automatically. As a work around, program the desired second address temporarily as the first address. Then read out CVs #17 + #18 and enter these values in CVs #67 + #68. Program the first address back to the original address, if used.
3.9	#69 - #82	Function mapping F0, F1 - F12	0 - 255	1, 2, 4, 8, 2, 4, 8, ...	Function mapping for F0 forward, F0 reverse and F1 - F12 for SECOND address
3.15	#83	Modify light effects	0 - 9	0	Change of the minimum dimming value

	CV	Denomination	Range	Default	Description
	#97	Change between single and consist address by function key	0 - 28	0	Using this key (only on the main address), you can switch between the main address of the decoder (on CV #1 or CVs #17, #18) or the consist address. But for this CV #21 and CV #22 must be set to CV value 0 and it replaces the command CV #22, Bit 6=1. = 1 - 28: Pressing the defined function key (1 - 28) switches to driving with the main address of the decoder (i.e. CV #1 or CVs #17, #18) despite the presence of a consist address (CV #19 > 0, and/or CV #20). ATTENTION: Defines an F button (0=none, 1=F1, 2=F2; 28=F28) which switches to the composite address (CV#19 or CV#19/20) when the first address (CV#1 or CV#17/18) is active. To do this, CV#21 and CV#22 must each be set to the CV value 0 (this is why the command CV#22.Bit6=1 is also replaced).
0	#107	Light suppression (i.e. front headlights AND additionally defined function output) at cab side 1 (front)	0 - 220	0	The value of this CV is calculated as follows: The number of a function output (F01 - F07) x 32 + number of a function key (F1, F2...F28) = Value of CV #107 Function Key: That key (F1 - F28) which should turn off ALL lights on the cab side 1 (front side) AND Function Output: i.e. taillights on the same side.
0	#108	Cab side 2 (rear)	0 - 220	0	Same as CV #107 but for other locomotive side.
0	#109	Light suppression Additional function output side 1	0 - 5 Bit 7 = 0,1		If CV #109, Bit 7 = 1 and CV #110, bit 7 = 1, the cab side light suppression in the Consist is automatically activated. Function output is switched off together with CV #107
0	#110	Automatische einseitige Lichtunterdrückung Weiterer FU-Ausgang Seite 2	0 - 5 Bit 7 = 0,1		If CV #109, Bit 7 = 1 and CV #110, bit 7 = 1, the cab side light suppression in the Consist is automatically activated. Function output is switched off together with CV #108
3.1 3.5 3.7 3.14	#112	Special ZIMO configuration Bits	0 - 255	2	Bit 1 = 0: Normal acknowledgment in "Service Mode"; by activating motor and headlight outputs. = 1: High frequency pulses instead of normal acknowledgments from motor and headlights. Bit 2 = 0: Loco number ID is OFF = 1: Loco number ID is ON Bit 3 = 0: 12-Function mode = 1: 8-Function mode Bit 4 = 0: Pulse chain recognition OFF = 1: P Pulse chain recognition ON (use with old LGB systems) Bit 5 = 0: Select between "short" or = 1: "long" second address Bit 6 = Märklin break section Bit 7 = 0: no pulse chain generation = 1: Generates pulse chain commands for LGB sound modules.

	CV	Denomination	Range	Default	Description
3.12	#114	Dim Mask 1 = Excludes certain function outputs from dimming per CV #60. For higher function outputs go to CV #152.	Bits 0 - 7	0	Enter function outputs that are not to be dimmed as per CV #60. These outputs will use the full voltage available from the decoder's positive pin. Bit 0 - front headlight, Bit 1 - rear headlight, Bit 2 - function output F01, Bit 3 - F02, Bit 4 - function output F03, Bit 5 - F04 Bit 6 - function output F05, Bit 7 - F06 Bit value = 0: Output will be dimmed to the value defined in CV #60. Bit value = 1: Output will not be dimmed. EXAMPLE: CV #114 = 60: F01, F02, F03, F04 are not dimmed; i.e. only the head lamps are dimmed.
3.12 3.15 3.16	#115	Uncoupler control or Second dim value	0 - 99	0	Only active as uncoupler if "uncoupler" function is selected (value 48) in CV #125 - #132, #159 or #160: Tens digit = 0: used for dimming. Ones digit (0 to 9): PWM - voltage reduction (0 to 90%)
Fehler! Verweisquelle konnte nicht gefunden werden.	#117	Flasher functions Outputs are assigned in CV #118.	0 - 99	0	Duty cycle for flasher function: Tens digit = OFF time Ones digit = ON time (0 = 100msec, 1 = 200msec 9 = 1 sec) Example: CV #117 = 55: Flashes evenly at 1 a second interval.
Fehler! Verweisquelle konnte nicht gefunden werden.	#118	Flashing mask - Defines which outputs operate as flashers as programmed in CV #117	Bits 0 - 7	0	Selected function outputs will flash when turned ON. Bit 0 - front headlights Bit 1 - rear headlights Bit 2 - function output F01 Bit 3 - F02 Bit 4 - F03 Bit 5 - F04. Bit value = 0: No flasher Bit value = 1: Output flashes when turned ON. Bit 6 = 1: F02 flashes inverse! Bit 7 = 1: F04 flashes inverse! (for alternate flashing, i.e. wig-wag) EXAMPLE: CV #118 = 12: F01 and F02 are defined as flashers. CV #118 = 168: Alternate flashing of F02 and F04
3.12	#119	Low beam mask for F6 - Output assignment for (example) low/high beam headlights ATTENTION:	Bits 0 - 7	0	Selected function outputs will dim with F6 key, according to the dim value in CV #60. Typical application: Low/high beam Bit 0 - front headlight, Bit 1 - rear headlight, Bit 2 - function output F01, Bit 3 - function output F02, Bit 4 - function output F03, Bit 5 - function output F04.

	CV	Denomination	Range	Default	Description
		Certain settings in CV #154 (Special output configurations) change the meaning of CVs #119 and #120 and therefore will no longer work as a low-beam mask.			Bit value = 0: Output will not be dimmed, Bit value = 1: Output will be dimmed with F6 to value defined in CV #60. Bit 7 = 0: normal action of F6. = 1: inverted action of F6. EXAMPLE: CV #119 = 131: Function key F6 toggles headlights between low and high beam.
3.12	#120	Low beam mask for F7	Bits 0 - 7		Same as CV #119 but with F7 as low beam key.
3.7	#121	Exponential Acceleration	0 - 99	0	Acceleration time (momentum) can be stretched in the lower speed range: Tens digit: Percentage of speed range to be included (0 to 90%). Ones digit: Exponential curve (0 to 9). EXAMPLE: CV #121 = 11, 23 or 25 are typical initial test values.
3.7	#122	Exponential Deceleration	0 - 99	0	Deceleration time (momentum) can be stretched in the lower speed range: Tens digit: Percentage of speed range to be included (0 to 90%). Ones digit: Exponential curve (0 to 9). EXAMPLE: CV #122 = 11, 23 or 25 are typical initial test values.
3.7	#123	Adaptive Acceleration and braking	0 - 99	0	The increase or decrease of the set speed should only be done after a defined approach of the actual speed to the previously specified set speed. CV #123 contains the speed step distance which must be reached. = 0: no adaptive method Tens digit: 0 - 9 for acceleration. (1 = strong effect) Ones digit: 0 - 9 for braking = 11: the strongest effect
3.7 3.17	#124	Shunt key functions (not in use) Switching SUSI - Logic Level Outputs	Bits 0 - 4, 6	0	Bits 0 - 4, 6: Selection of a shunting key for the ACTIVATION of the HALF SPEED: Bit 5 = 1: "DC holding sections". Bit 7 = 0: SUSI interface active (or servos, if defined in CVs #181, #182, ... = 1: Logic level activated instead of SUSI.
3.15	#125	Special effects American lighting effects as well as others such as uncoupler, smoke generator and more on		0	Bits 1, 0 = 00: bidirectional (active in both directions) = 01: only active in forward direction = 10: only active in reverse direction ATTENTION in case of CV #125 and #126: change CVs #33, #34.... if direction is wrong! Bits 7, 6, 5, 4, 3, 2 = effect-code EXAMPLES You want: Program CV #125 to: Mars light forward only - 0000101 = 5 Gyalite independent of direction - 0001100 = 28 Ditch type 1 left, only forward - 00100101 = 37

	CV	Denomination	Range	Default	Description
		function output F0 (front headlight) Effects can be further adjusted and modified with CVs #63, #83 and CV #115, #116 (for uncoupler).			Uncoupler - 00110000 = 48 Soft start of output - 00110100 = 52 Automatic stop light - 00111000 = 56 Automatic cab light OFF - 00111100 = 60 Auto. smoke OFF after 5 min - 01000000 = 64 Auto. smoke OFF after 10 min - 01000100 = 68 Speed/load depen. smoke - 01001000 = 72 Speed/load depen. diesel smoke - 01010000 = 80
3.15	#126	Special effects for rear headlight (default F0 reverse)		0	Like CV #125 #125 → Front Headlight #126 → Rear Headlight
3.12 3.15	#127 - #132	Effects on F01, F02, F03, F04, F05, F06		0	Like CV #125 #127 → F01 #128 → F02 #129 → F03 #130 → F04 #131 → F05 #132 → F06
3.15	#137 #138 #139	Characteristic curve for smoke generator at one of the FOs 1 - 6 PWM at standstill PWM when driving PWM acceleration	0 - 255 0 - 255 0 - 255	0 0 0	Effective if one of the function effects "smoke generation" (i.e. "72" or "80") is assigned in one of the CVs #127 - #132: The three values in CVs #137 - #139 define a characteristic curve for the function output in question (F01 - F08, referred to below as FOx). CV #137: PWM of the FOx at standstill CV #138: PWM of the FOx at constant speed CV #139: PWM of the FOx during acceleration
3.1	#144	Programming and update locks	0, 64, 128, 192		= 0: no programming and update lock Bit 6 = 1: programming lock in "Service mode" Bit 7 = 1: software update lock via MXDECUP, MX31ZL or other means.
3.7	#151	Reduction of motor control in Consist. or Motor brake (If address NOT in Consist)	Tens Digit 1 - 9	0	Tens digit 1 - 9 reduces the motor braking to 10 - 90 % of the value according to CV #58. = 0: no motor brake = 1 - 9: If despite "zero energy supply to the motor" (motor PWM zero) the target speed is not reached (speed still too high), motor brake is applied slowly (distributed over 1, 2, ... 8 sec until full effect by motor short-circuit via the output stage). The higher the value, the stronger the application of the motor brake. = Tens digit (1-9): Reduction of the motor braking can be set when the Consist key is active. The values 1-9 in the Tens digit of CV #151 reduce the motor braking to 10% - 90% of the value set in CV #58.
3.12	#152	Dimming mask 2 (Exclusion of certain function	Bits 0 - 5		... Continuation of CV #114. Bit 0 - function output F07, Bit 1 - function output F08, Bit 2 - function output F09,

	CV	Denomination	Range	Default	Description
		outputs from dimming) Continuation of CV #114 and F03, F04 as direction outputs	and Bit 6, Bit 7	0 0	Bit 3 - function output F010, Bit 4 - function output F011, Bit 5 - function output F012. Bit 6 = 0: „normal“ = 1: "Direction bit" at F03 and F04 that is, F03 is switched on when driving in reverse, F04 is switched on when driving forward (normal mapping of F03 and F04 is invalid when this Bit is set). (for Märklin loop switch with C-type) Bit 7 = 1: "Direction bit" for F09 when moving forward
3.7	#155	Selection of a function key for half speed	0, 1 - 28 29, 30	0	Determination of the function key with which the half speed can be activated.
3.7	#156	function key for deactivating the acceleration and deceleration times	0, 1 - 28 29, 30 129 - 156, 157, 158	0	Determination of the function key with which acceleration and deceleration times are deactivated.
3.7	#157	Selecting a function key for the MAN function Only for non-ZIMO systems, which don't have the MN key.	0, 1 - 28, 29	0	The MAN function (or MAN key on ZIMO cabs) was originally designed for ZIMO applications only, in order to cancel stop and speed limit commands applied by the signal-controlled speed influence system (HLU). This function was expanded in later software versions to include "asymmetrical DCC signal stops" (Lenz ABC). If ZIMO decoders are used with non-ZIMO systems, a function key can now be assigned with CV #157 to cancel a signal-controlled speed limit or stop command.
3.12 3.15	#159 #160	Special effects for F07, F08		0	See CV #125 for details #159 → F07 #160 → F08
3.18	#161	Servo outputs: Protocol	Bit 0 - 2, 4 - 7 NOTE: CV #161 must be set to "2" for Smart Servo RC-1!	0	Bit 0 = 0: Servo protocol with positive pulses. = 1: Servo protocol with negative pulses. Bit 1 = 0: Control wire only active during movement = 1: ... always active (consumes power, vibrates at times but holds position even under mechanical load) - this setting is also required for SmartServo RC-1 (with memory wire)! Bit 2 = 0: Moves to center position, if defined for two-key operation (see CV #181/#182), when both function keys are OFF. = 1: Servo runs only if function keys are pressed when in two-key operating mode (see CV #181/#182). Bit 4 = 1: Servo oscillates between the end points in forward direction. Bit 5 = 1: like bit 4 but in reverse direction of travel Bit 6 = 0: Servo1 for first address = 1: Servo1 for secondary address Bit 7 = 0: Servo2 for first address = 1: Servo2 for secondary address

	CV	Denomination	Range	Default	Description
3.18	#162 #163 #164 #165	Servo 1 Left Stop Right Stop Center Position Rotating Speed	0 - 255 0 - 255 0 - 255 0 - 255	49 = 1 ms Servopulse 205 127 30 = 3 sec	End positions and center position define the portion of the total rotation range of the servo to be used (typ. approx. 270°). "left", "right" are to be understood symbolically; actual effect can also be exactly the opposite. Speed of the actuating movement: Time between the defined end positions in tenths of a sec (i.e. range up to 25 sec, default 3 sec).
	#166 - #169 #170 - #173 #174 - #177	Servo 2 Servo 3 Servo 4			As above for servo 1
3.18	#181 #182	Servo 1 Servo 2 Function assignment NOTE: If a servo control line shares its pin with another function (e.g. SUSI or input) for optional use, a value >0 in CV #181, #182, ... means switching to servo control line. This concerns with "small" decoders (scale N ... H0) the "official" SUSI pins, which are switched to servo with CVs #181, #182 (SUSI no longer available)	0 - 28 90 - 97 101 - 114	0 0 0 0	= 0: Servo not in operation = 1: Single-key operation with F1 = 2: Single-key operation with F2 and so on to = 28: Single-key operation with F28 = 90: Servo action depends on loco direction: forward = turns left; reverse = turns right = 91: Servo action depends on loco stop and direction: turns right when stopped and direction is forward, otherwise turns left. = 92: Servo action depends on loco stop and direction: turns right when stopped and direction is reverse, otherwise turns left. = 93: Servo action depends on loco movement: turns right when loco stopped, left when loco moving; direction makes no difference. = 94: refers to the function "Panto1" according to CV #186. = 95: ... "Panto2" according to CV #187. = 96: ... "Panto3" according to CV #188. = 97: ... "Panto4" according to CV #189. = 101: Two-key operation F1 + F2 = 102: Two-key operation F2 + F3 etc. = 111: Two-key operation F11 + F12 = 112: Two-key operation F3 + F6 = 113: Two-key operation F4 + F7 = 114: Two-key operation F5 + F8 (Two-key operation according to CV #161, bit 2)
	#185	Special assignment for real steam Locos		0	= 1: Steam locomotive with single servo operation; speed and direction by speed controller, center position is stop. = 2: Servo 1 proportional at cab, servo 2 at direction function. = 3: like 2, but: direction servo automatically in zero position, if speed level 0 and F1 = on; At speed level > 0: direction servo on direction. NOTE to CV #185 = 2 or 3:

	CV	Denomination	Range	Default	Description
					Servo 1 is adjustable by CV #162, #163 (end positions), reversal of direction is also possible by appropriate values. Servo 2 is adjustable by CV #166, #167.
	#186 #187	"Panto1" "Panto2"		0	Bit 7 = 0: Not sound dependent = 1: Sound-dependent Bit 6 - 5 = 00: Direction independent, = 01: only for forward travel = 10: only when driving backwards = 11: only if function key is switched off Bit 4 - 0: key to activate 00001 = F1 00010 = F2 00011 = F3, ...
3.15	#190	Fade-in time for effects 88, 89, 90	0 - 255	0	Dimming up/down timings for effects 88, 89, 90
3.15	#191	Fade time for effects 88, 89, 90	0 - 255	0	Dimming up/down timings for effects 88, 89, 90
3.12 3.15	#195 #196	Effects on F09, F010		0	Like CV #125 #195 → F09 #196 → F010
3.2	#250 #251 #252 #253	Decoder-ID also contains a code (in CV #250) that identifies the decoder type	Read only	-	The decoder ID (serial number) is automatically entered during production: The first Byte (CV #250) denotes the decoder type; the three other Bytes contain the serial number. The decoder ID is primarily used for automatic address recognition when an engine is placed on the layout track (future function) as well as in conjunction with the "load code" for "coded" sound projects (see CV #260 - #263).
3.19	#264	Einstellung des Ausgangs „Niederspannung" der Decoder MX675V... MX676V..	Bit 0 - 7	15	Decimal 0 - 7: 1.5 V - 17 V
3.15	#353	Automatic shutdown of the smoke generator	0 - 255 = 0 - 106 min	0	For effects "010010xx" or "010100xx" (smoke generator): Protection against overheating: switch-off ½ min to approx. 2 h. = 0: no automatic switch-off, = 1 to 255: autom. switch-off after 25 sec / unit
3.11	#399	Speed-dependent high beam (According to "Rule 17")	0 - 255	0	In connection with "Swiss Mapping" at special setting "high beam", see CV #431 = 255; for each of the 13 CV groups (CV #437, #443, ...): Switch to high beam only if speed is higher than value in this CV (255 speed steps). EXAMPLES and SPECIAL CASES: = 0: High beam at any speed (also at standstill), only controlled by F-key (e.g. according to CV #430). = 1: High beam when driving (NOT at standstill), otherwise only controlled by F-key (e.g. according to CV #430).

	CV	Denomination	Range	Default	Description
					= 128: High beam from half speed.
3.11	#430	Swiss Mapping Group 1 "F-Key"	0 - 28, 29 (for F0) 129 - 157	0	The key defined here shall turn on the function outputs listed under A1 (forward or reverse) and A2 (forward or reverse). 1 - 28 for function keys F1 - F28, F29 is for F0. Bit 6 = Swiss Mapping group applies to SECOND address. Bit 7 = 1: Inverts the F-key function.
3.11	#431	Swiss Mapping Group 1 "M-Key" or Special high-beam setting	Bit 0 - 6: 0 - 28, 29 (for F0) and Bit 7 or 255	0	The "normal function mapping" (according to CVs #33-#46) for the "M-key" defined here will be deactivated (that is the assigned outputs) when the "F-key" is switched on. Bit 5 = 1: The M-key outputs shall not be turned OFF if the F-key is ON and driving backwards. Bit 6 = 1: The M-key outputs shall not be turned OFF if the F-key is ON and driving forward. Bit 7 = 1: the outputs listed under A1 and A2 should only switch ON if the F and M key are ON. = 157: is an often-used value for this CV, because F0 (= 29) is usually selected as the "M-key" with Bit 7 = 1: F0 then acts as a general ON/OFF key. = 255 (Special high-beam setting!): the FU-Outputs defined in the following four CVs are switched to full intensity, provided that they are controlled via the "normal function mapping", and dimmed with CV #60 or dimming group; this function is used, for example, to switch the headlights of a Swiss locomotive to high-beam, without switching the white taillight to high-beam. Depending on CV #399 setting: High beam is only switched on if the speed is higher than the value given in this CV.
3.11	#432	Swiss Mapping Group 1 "A1" forward	Bits 0 - 3: 1 - 12 14 (FA0v) 15 (FA0r) Bits 5 - 7: 0 - 7	0	Bits 0 - 3: Function output to be switched ON in forward direction provided that both the "F" and "M" keys are ON (if Bit 7 for the "M" key of this group is 1, otherwise "F" key ON is sufficient). Bits 5 - 7 (7 possible values or zero): Number of the applicable dimming CV. For example: Bit 5 = 1 means dimming according to CV #508 etc.
3.11	#433	Swiss Mapping Group 1 "A2" forward	Bits 0 - 3: 1 - 12 14 (FA0v) 15 (FA0r) Bits 5 - 7: 0 - 7	0	Bits 0 - 3: Additional function output to be switched ON in forward direction provided that both the "F" and "M" keys are ON (if Bit 7 for the "M" key of this group is 1, otherwise "F" key ON is sufficient). Bits 5 - 7 (7 possible values or zero): Number of the applicable dimming CV. For example: Bit 5 = 1 means dimming according to CV #508 etc.
3.11	#434	Swiss Mapping Group 1 "A1" reverse	As above	0	As above but for reverse direction

	CV	Denomination	Range	Default	Description
3.11	#435	Swiss Mapping Group 1 "A2" reverse	As above	0	As above but for reverse direction
3.11	#436 - #441	... - Group 2	...	0	All 6 CVs of Group 2 are defined the same way as the 6 CVs in group 1.
3.11	#442 - #447	... - Group 3	...	0	All 6 CVs of the following groups are defined the same way as the 6 CVs in group 1.
3.11	#448 - #453	... - Group 4	...	0	...
3.11	#454 - #459	... - Group 5	...	0	...
3.11	#460 - #465	... - Group 6	...	0	...
3.11	#466 - #471	... - Group 7	...	0	...
3.11	#472 - #477	... - Group 8	...	0	...
3.11	#478 - #483	... - Group 9	...	0	...
3.11	#484 - #489	... - Group 10	...	0	...
3.11	#490 - #495	... - Group 11	...	0	...
3.11	#496 - #501	... - Group 12	...	0	...
3.11	#502 - #507	... - Group 13	...	0	...
3.11	#508 - #512	Dimming values for "Swiss Mapping" Special Settings	(0- 31)*8 (only Bits 7 - 3 are used) Bits 0 - 2	0	Each group CV (i.e. #432, #433, #434, #435) can be linked to one of these five dimming CVs. The value to enter is the dimming value (0 - 31) times the function output number. (i.e. dimming value = 16 for function output 6: 16 x 6 = 96 is the value to enter). This will dim the relevant function outputs accordingly. Only with function outputs F00 to F013. Bit 0 = 1: suppresses the light effect Bit 1 = 1: Flashing effect Bit 2 = 1: Inversed flashing effect

	CV	Denomination	Range	Default	Description
3.11	#800 - #805	... - Group 14.	...	0	...
3.11	#806 - #811	... - Group 15.	...	0	...
3.11	#812 - #817	... - Group 16.	...	0	...
3.11	#818 - #823	... - Group 17.	...	0	...
3.15	#850 - #864	Effects („new Level“)		0	Preconnected effects for the outputs " Front Headlight ", " Rear Headlight ", FA1, FA2, ... SEE description before table!

5 Calculation of the long second loco address

Programming the second loco address works like for the first address, except that for the first, the system automatically calculates the corresponding values for CVs #17 & #18. CVs #67 & #68 have to be calculated by the user. This is done with the following formula:

$$\text{CV \#67} = \text{desired address} / 256 \text{ (only the digits BEFORE the point)} + 192$$

$$\text{CV \#68} = \text{desired address} - ((\text{CV \#67} - 192) * 256)$$

Example: the desired address is 10111:

$$\text{CV \#67} = 10111/256 + 192 = 39 + 192 = 231$$

$$\text{CV \#68} = 10111 - [(231 - 192) * 256] = 10111 - (39 * 256) = 10111 - 9984 = 127$$

Alternatively, it is possible to program the desired long second address into CVs #17 & #18 (for the first address) and have the system convert it. Then write the converted values of CV #17 & #18 into CVs #67 & #68. Afterwards, the user has to reprogram the first long address (if it was used).

The calculation of the long second address for CV #17 and #18 can also be done with this online calculator: http://www.opendcc.de/info/decoder/dcc_cv.html (scroll down to CV #17, #18)

6 Service Notes

Also, ZIMO decoders can become defective ... sometimes "by themselves", sometimes by short circuits in the wiring, sometimes by a failed update ...

These defective decoders can of course be sent to ZIMO to be repaired or replaced here. Regardless of whether this is a warranty case or a repair that has to be paid for, the sender should get back a decoder that is not only functional but also configured in the same way as the original one (i.e. mainly the same CV values and the same sound project).

In most cases, the microcontroller and memory of the decoder is not defective in repair cases, so that the decoder can be read out in the repair shop.

To be absolutely sure that important stored data is not lost, you should

SAVE IMPORTANT DATA from the decoder, i.e. **READ OUT**, as long as it is possible without any problems, i.e. the decoder is not defective, in order to communicate them to ZIMO in case of repair if necessary or to have them available for a replacement decoder yourself:

- - loaded SW version (CVs #7, #65)
- - activated CV set if applicable
- (Activation code for CV #8, concerns non-sound decoder)
- - decoder ID (CVs #250 - #253, if available)
- - loaded code (CVs #260 - #263, concerns sound decoder), if applicable
- - loaded sound project

It would also make sense to read out and save the entire CV list, in order to read it back into the deleted or new decoder after a repair (where sometimes a "hard reset", i.e. resetting the CVs to default values, cannot be avoided) or after replacing the decoder. This (read out and read in) can be done with the help of

- program "ADaPT" (from E.Sperrer, works with Zimo and some other DCC systems)
- ZSP (works with MX31ZL MXDECUP or, in the future, with MXULF or MX10) or with
- ZSC (works with MXULF and in the future with MX10).

FURTHER NOTES concerning the sending in of defective decoders:

- In order to avoid unnecessary repair submissions, it should be checked beforehand if there is really a defect that needs the ZIMO workshop to fix. Quite a few of the decoders sent in are only "misconfigured" and would only have required a "hard reset" (CV #8 = 8) to reset the CV values to decoder default or sound project default.
- For example, if it is "only" a very bad driving behavior, it is useful to contact ZIMO Service (service@zimo.at) before sending in the decoder; often simple troubleshooting measures can then be recommended.
- ZIMO can only accept decoders for repair, NOT vehicles or vehicle parts with built-in decoders. Of course, there are exceptions after prior agreement in problem cases that have to do with the interaction of locomotive and decoder.
- The defect (or reason for sending in) should be described as precisely as possible, in addition to the above-mentioned basic information about the product sent in.
- So-called "OEM decoders", i.e. those that have been factory-installed by vehicle manufacturers in their own vehicles and are then delivered as a completely digitized locomotive, actually fall under the responsibility of the vehicle manufacturer. Nevertheless, ZIMO will perform repairs on such decoders if they are sent to ZIMO Service. The warranty and repair conditions may of course differ from

those of the vehicle manufacturer (whether "better" or "worse" is rather a matter of chance). Also in these cases: send only decoders to ZIMO, not complete locomotives!

In case of replacement of the decoder, in most cases the sound project contained in the original OEM decoder can also be used in the replacement decoder (as far as the necessary information has been entered in the repair form). This applies to vehicle manufacturers such as Roco, Fleischmann, Wunder, Demko, and many others, but there may also be manufacturers where the sound projects are not available from ZIMO, but are purely "self-made".

- "Preloaded" sound projects (see [Sound Database](#)), on the other hand, are usually NOT available at ZIMO, but only at the author / owner, who usually also supplies the decoder together with the ready-loaded sound project himself or is connected with the supplier. Such sound decoders are therefore in case of repair better to work on the immediate supplier. Equally good to be handled by ZIMO directly are of course those cases where it is a clear hardware problem (i.e. if motor or function output is defective).

ATTENTION: Sometimes decoders appear defective when a loaded sound project or its built-in CV list assumes a certain model (e.g., a certain lighting equipment and order), but the locomotive's equipment or wiring does not match it. Typical cases: Light does no longer work with F0 (because the sound project has diverted the light to other functions), or loco starts "uncontrolled" (because the sound project has activated a servo coupler and the " coupling waltz").

NOTE for this: for the individual sound projects in the ZIMO Sound Database, there are usually also variants that only contain the sound and do not require specially converted vehicles.

Repair Form

download and print from the following link: www.zimo.at

(www.zimo.at -> Sales -> Customer Service (Repairs) -> ZIMO Repair-Form)

The image shows a screenshot of the 'ZIMO REPARATUR' form. At the top, it says 'ZIMO REPARATUR zur Beilage für Reparatur-Einsendungen oder -Abgaben, auch für Garantiefälle'. Below this, there are sections for 'Zuordnung (nur von ZIMO auszufüllen)', 'WICHTIGE DATEN für Decoder', and 'Reparatur-/Produkt (nur von ZIMO auszufüllen)'. The form includes fields for name, address, phone, and email, as well as checkboxes for various repair options like 'Schleifen System ausgerollt' and 'Garantie-Anerkennung'.



ZIMO Elektronik GmbH
Schönbrunner Str. 188 A - 1120 Wien