

Operator Manual V1.0

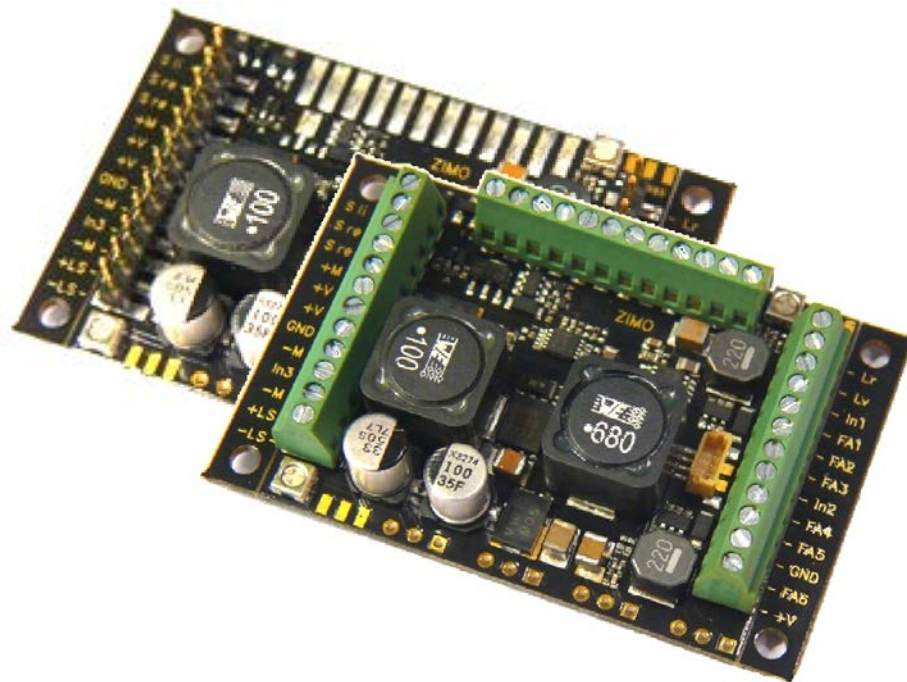

G-scale- SOUND – DECODER & DECODER MX695LS, -LV, -KS, -KV, -KN MX696 -V, -S, -N, MX697

Table of Contents

- 1 Model - Overview 2
- 2 Technical Data and Characteristics 3
- 3 Installation and Wiring of the MX695 / (MX696) 4
- 4 Configuration of the MX695 / (MX696) / (MX697) 8
 - 4.1 Programming in "Service mode" (on the programming track) 8
 - 4.2 Programming in "Operational mode" (on-the-main "PoM") 8
 - 4.3 Decoder-ID, Load-Code, Decoder-Type and SW-Version 9
 - 4.4 Engine adresse(s) in digital mode 9
 - 4.5 Decoder powered consist function (also: "advanced consist") 10
 - 4.6 Analog mode 10
 - 4.7 Motor activation and motor control 11
 - 4.8 Acceleration and Deceleration: 14
 - 4.9 Special Mode of Operation "km/h – speed regulation" 15
 - 4.10 ZIMO "signal controlled speed influence" (HLU) 15
 - 4.11 Signal Control using "asymmetrical DCC-Signal" (Lenz ABC) 16
 - 4.12 DC Brake Sections (Märklin brake-mode) 17
 - 4.13 Distance Controlled Stopping - Constant Stopping Distance 17
 - 4.14 Shunting and Half-Speed, MAN-Functions: 18
 - 4.15 Function Mapping as per NMRA-DCC-Standard 19
 - 4.16 The extended ZIMO Function mapping 20
 - 4.17 The ZIMO „Input-Mapping“ 23
 - 4.18 Dimming and low beam 23
 - 4.19 Flashing-Effect 24
 - 4.20 Special Effects for Function-Outputs (american and other light effects, smoke generator, coupling, et al.) 25
 - 4.21 Configuration of smoke generators 26
 - 4.22 Configuration of electric decoupler 26
- 5 ZIMO SOUND – Selecting and Programming 27

Note

ZIMO Decoder contain a microprocessor, with a software version, that can be determined in the configuration setting of CV # 7 (version number), and CV # 65 (sub version number).

Any then current version may not be correctly represented in this user guide. Similarly to computer programs it is not always possible to verify all of the functionality and guarantee that all function in any and all of the various application combinations.

New software version can always be loaded into the hardware and ZIMO decoder can even be update by the users. As described in the chapter „Software-Update“.

Software updates installed by the user are free of charge (except for the cost of the programming unit unless you own a ZIMO MX10 or MX32ZL). Update or rebuilds at the ZIMO service center are typically not free of charge and are not considered warranty repairs. Warranty repairs are restricted to hardware problems only, unless they were caused by the user connecting operational elements to the board(s). For updates visit www.zimo.at !

1 Model - Overview

The MX695 G-scale decoder is available in three different models of which 4 are with sound. In addition there also will be special versions with adapted functionality (i.e. adapted number of available outputs.).

ZIMO Decoders have the **NMRA-DCC data format** implemented and therefore operate with ZIMO DCC systems as well as with other DCC compatible systems., including systems based on the **MOTOROLA-Protocol (MM)** for Märklin and other MOTOROLA based command stations. ZIMO Decoders work also in **Analog Mode ((DC) –(Model railroad -Transformers, PWM- and Laboratory power supplies, as well as AC – Analog Mode (Transformers with high-voltage-impulse for directional control).**

51 x 40 x 12 mm

MX695K ...	Sound-Decoder with screw terminals
-------------------	---

MX695KV	Full Edition: 36 screw terminals 14 function outputs (including headlights) 1 special out for smoke generator fan 3 low voltage outputs: 5 V, 10 V, variable 4 Servo-Outputs (ea. 3-pin: control, ground, + 5 V) 2 variable controls (loudness, low voltage adjustment) 1 connection for electronic flywheel (capacitor input)
MX695KS	Reduced.: 28 screw terminals (2 x 12 and 1 x 4) 8 function outputs (including headlights) 1 low voltage output: 10 V 1 connection for electronic flywheel (capacitor input)

MX695L ...	Sound-Decoder with pin connectors
-------------------	--

MX695LV	Full Edition: 3 pin connectors, ea 12-pins 14 function outputs (including headlights) 1 special out for smoke generator fan 3 low voltage outputs: 5 V, 10 V, variable 4 Servo-Outputs (ea. 3-pin: control, ground, + 5 V) 2 variable controls (loudness, low voltage adjustment) 1 connection for electronic flywheel (capacitor input)
MX695LS	Reduced: 2 pin connectors, ea. 12-pin (matching ESU-interface) 4 soldering pads for additional connections 8 function outputs (including headlights) 1 low voltage output: 10 V 1 connection for electronic flywheel (capacitor input)

51 x 40 x 12 mm

MX695KN	Non-Sound-Decoder with screw terminals
----------------	---

MX695KN	Non-Sound-Decoder with screw terminals 20 screw terminals (1 x 8 and 1 x 12) 8 function outputs (including headlights) 1 low-voltage output: 10 V 4 Servo-Outputs (ea. 3-pin: control, ground, + 5 V) 2 Variable controls (loudness, low-voltage adjustment)
----------------	--

55 x 26 x 16 mm

MX696 ...	(Sound-) Decoder with style & connection technology as the MX690 / MX69
------------------	--

MX696V	Full edition: 2 16-pin connectors & 4 screw terminals 14 function-outputs (including headlights) 1 low-voltage output: variable (1,2 V - track) 4 Servo-outputs (control line)
MX696S	reduced: 1 16-pin connectors & 1 10-pin connectors & 4 screw terminals 8 function-outputs (including headlights)
MX696N	non-sound: 1 16-pin connectors & 4 screw terminals 8 function-outputs (including headlights)

MX697	To be announced
--------------	------------------------

2 Technical Data and Characteristics

Track Voltage using digital control (DCC)	10 - 30 V
Electric strength (peak) in analog mode (High voltage pulse for direction reversal)	35 V
Threshold voltages in analog mode - see below !	
Maximum continuous motor output = maximum continuous total output	6 A
Maximum peak current (Motor only or total)	10 A
Number of function outputs	MX695KV, MX695LV 14
	MX695KS, MX695LS, MX695KN ... 8
Maximum continuous total output per function group	2 A
Maximum continuous output for low-voltage functions (5 V, 10 V, adjustable)	each 1 A
Voltage range for adjustable low-voltage functions (MX695KV, -LV)	1,5 to 16 V
Maximum current at special output for Smoke-Ventilator (5 V - Motor) with brake function	200 mA
Storage capacity for sound samples	32 Mbit
Sample rate depending on individual characteristics of the selected sound samples ...	11 or 22 kHz
Numer of simultaneously playable sound channels	6
Sound-amplifier output at 4 Ohm	Sinus 10 W
Impedance of speakers	8 Ohm, 2 x 8 Ohm parallel, 4 Ohm
Externally connection for electronic flywheel	Load voltage 17 V
for standard capacitor	>= 20 V, any capacity
gold-caps (pack with 7 pieces each 2,5 V - in series) >= 17 V, max. 1 F	
Rechargeable battery (only with special circuitry)	14,4 V pack
charge current for external energy storage	80 mA
Analog mode (continuous current, alternating current)*) Threshold voltage headlights	ca. 4 V
	Threshold voltage Sound
	Threshold voltage motor-activation ca... 6 V
Operating temperature.....	- 20 to 100 °C
Dimensions (L x W x H including pinss) **)	MX695KV, -KS 50 x 40 x 14 mm
(L x W x H including screw terminals)	MX695LV 50 x 40 x 14 mm
(long plugin terminals for ESU-loco board)	MX695LS 50 x 40 x 20 mm
	MX696 55 x 26 x ca. 16 mm

*) Actual analog-characteristics strongly dependent on vehicle model and engine (transformer output voltage may fail due to overload)

**) Length given without break-away mounting brackets; increase the length by 2 x 6 mm

OVERLOAD PROTECTION

The motor and function outputs of the ZIMO large-scale decoders are designed with large reserve capacities and are additionally protected against over-currents and short circuits. Automatic shutoff will occur in case of overload followed by automatic reboots. (A Common side effect is blinking lights).

These safety precautions do not mean that the decoder is indestructible. Please pay attention to the following:

Faulty decoder hook-up (mixed up connection wires) and improper electric connections between the motor terminal and chassis are not always recognized and can lead to output driver damage or even total destruction of the receiver.

Unsuitable or defective motors (e.g. with short-circuited turns or collectors) are not always recognizable by their high consumption of electricity (only peaks may register) and can lead to decoder damage, sometimes long term effects can cause output driver defects.

The decoders output drivers (for the motor and function outputs) are not only at risk through over-current but also through **voltage spikes** as they are delivered from the motor and other **inductive consumers**. Depending on track voltage, such spikes can reach several hundred volts and are absorbed by special protection circuits inside the decoder. The capacity and speed of such elements is limited and so unnecessarily high track voltage should not be used. Never use a higher voltage than recommended for a particular vehicle. Only in exceptional cases should the ZIMO adjustable range (up to 24 V) be utilized.

THERMAL PROTECTION

All ZIMO decoders come equipped with a sensor that detects the actual temperature. Once the maximum permissible value (ca. 100 °C on the circuit board) has been reached, power to the motor will be shut off. Rapidly flashing headlights (at ca. 10 Hz) will signal that a shut-off has occurred. Motor operation will resume automatically after a drop in temperature of about 20 °C, typically after 30 to 60 sec.

SOFTWARE UPDATE

ZIMCO decodes are designed so that software updates can be completed by the user. This requires a device with an update function (ZIMO decoder update module **MXDECUP**, or **MXULF**, or "central system cab" **MX31ZL/MX32ZL**, or command station **MX10**). The update itself is carried out via a USB stick (**MXULF**, **MX31ZL**, **MX32ZL**, **MX10**) or via a computer with the "ZIMO Sound Programmer" **ZSP** software or "ZIMO Rail Center" **ZIRC** software.

There is no need to remove the decoder; the locomotive does not need to be opened; it can be placed onto the update-track (connected to the update-device) without any changes and can then be updated via a USB stick or a computer.

Note: Locomotive accessories that are directly connected to a track (not controlled by the decoder) may interfere with the update; in that case the locomotive will have to be opened and removed from the track.

3 Installation and Wiring of the MX695 / (MX696)

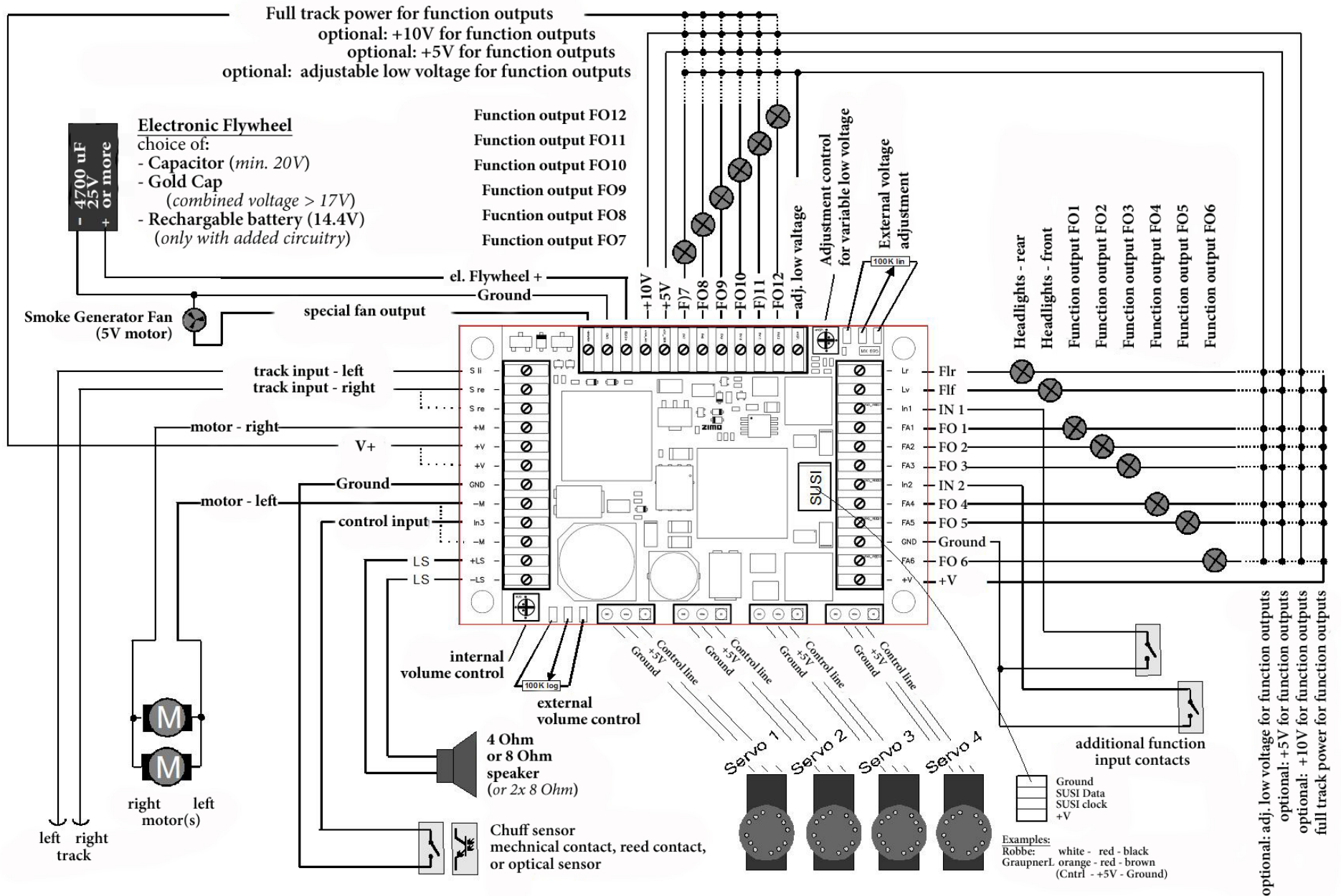

3.1 Track and Motor(s)

Find or make room for the decoder in the engine in order to accommodate the decoder easily.

All direct connections that are present in the original wiring configuration between the power pick-ups (wheels & pickup shoes) and the motor(s) must be separated. Even the headlights and other additional accessories must be completely isolated.

Connect track (wheel and pick-up shoes) and motor to their positions on the screw terminals as shown in the illustration. The sometimes present second connection points can, but don't have to be used.

Practically all common DC-motors used in your models (commercial and kitbashed) can be utilized.

In case that more than one motor is present in the vehicle, they will be parallel connected to the decoder. The parallel connection will result in an automatic synchronization if all motors are identical and use identical gear boxes. The MX695 is typically powerful enough to drive both motors.

See Configuration (CV's) for motor-control!

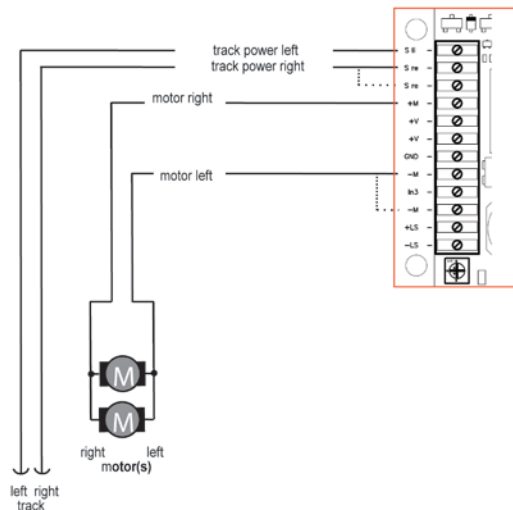

3.2 Speaker and Cam Sensor, Volume Control

Any 4 Ohm and 8 Ohm speakers can be used, or several speakers can be used in a parallel/serial connection as long as the total impedance is not less than 4 Ohm.

The sound amplifier for the MX695 works with a voltage of 10.8 V and has a sinus output of 12 Watt with a 4 Ohm speaker; with an 8 Ohm speaker it's less, approx. 6 Watt.

If you connect in parallel tweeters to the main speaker then they shall be connected via a crossover (for instance 10 uF capacitor).

Naturally the speaker (or several speakers together) must be able to withstand the output. This means that the volume must be cut back accordingly on lower rated speakers.

The "virtual chuff sensor technology" is very sophisticated and equivalent to physical chuff sensors. Therefore there is no advantage installing a cam sensor (for chuff synchronization to the wheel rotation).

In case a "real" chuff sensor is desired, a mechanical contact, a photo transistor, or a hall-sensor can be connected to the gate input "IN 3". The particular element must create a low-ohm connection (meaning < 10 K) between the gate input and GROUND when it generates impulses that are synchronized to the wheel rotation.

The volume can be adjusted by an internal and/or external potentiometer in addition to the software control via CV#266. The manual volume control is highly desired for Analog operations.

When an external potentiometer (100 K, preferably type audio/logarithmically) is inserted, the potentiometer on the circuit board needs to be turned up to full volume (counter clockwise) unless the internal potentiometer is setting a limit for maximum volume to protect a lower wattage speaker.

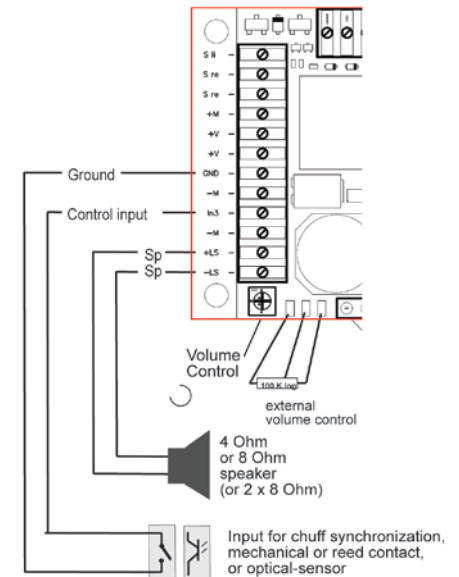

3.3 Function-Equipment and Function-Low Voltage

“Function Equipment” is all equipment that is connected to the function-outputs FLf, FLr, and FO1 (FO1)...FO12 (FO12). This is mostly lighting equipment (light bulbs and LEDs) but also operating magnets, small motors, relays, etc.

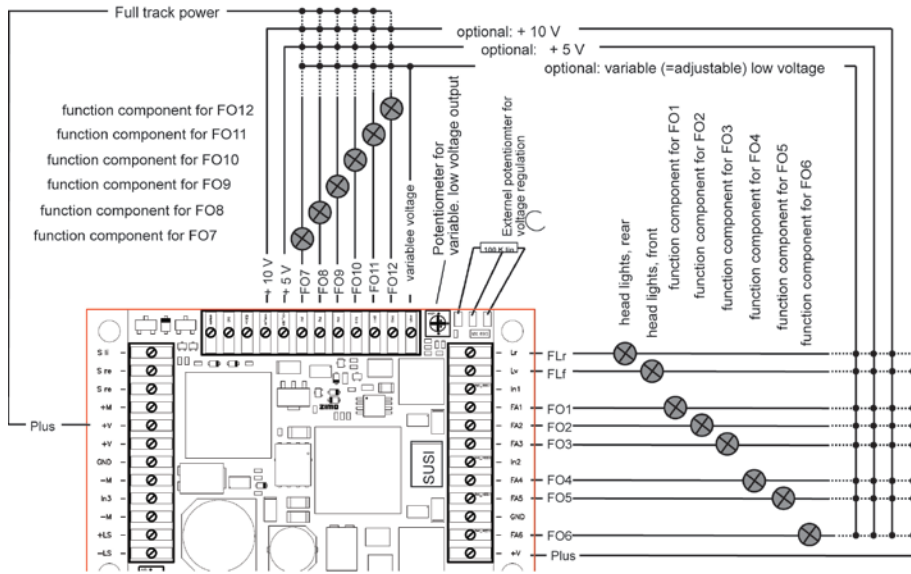

Each function-equipment (lamps, groups of lamps, etc.) is switched between the corresponding function-output (minus) and one of up to four positive voltage supply sources (plus).

- Positive terminal – full track voltage: the rectified constant track voltage; which is more or less instable, depending on the stabilizing on the quality of the digital-command station/booster. This means the voltage fluctuates with the track power.
- 000- Low Voltage - 10 V: this is the voltage which is generated in the decoder: mainly for the sound amplifier. ATTENTION: too high or unstable usage by the function equipment from this voltage source can impair the sound quality.
- Low Voltage - 5 V: this voltage is used for operating the Servos and is also available for the function equipment such as the typical 5 V light bulbs.

- ⚠ **Note:** Only available in the MX695KV, MX695LV, and other ..V- type models !
 - Variable low voltage: using the potentiometer on the decoder circuit board, or if desired using a controller (100K lin) externally connected to the three solder pads, the function voltage can be selected between ca. 1.5 V and the full track voltage.
- ⚠ **Note:** Only available in the MX695KV, MX695LV, and other ..V- type models !
- ⚠ **Note:** The usage of a true low voltage source is preferred over PWM dimming (CV # 60). PWM uses full voltage impulse with corresponding duty cycle which can cause damage to light bulbs if the PWM cycle is 3 or more (LEDs are not effected).

3.4 Special Connection for Smoke Fan

See Chapter Decoder Configuration (CV's) for “function mapping”, function effects electric coupling (Krois system, Heyn) etc.

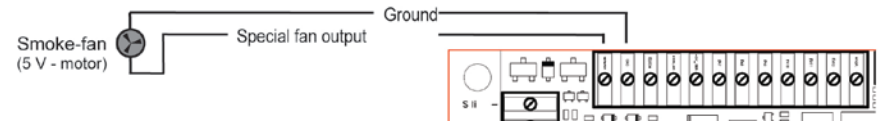

This output is used to power the fan motor for chuff or load synchronized applications. Those smoke units are either already available in the locomotive or can be additionally purchased.

What is distinct about this output (this is different from “normal” function outputs) is the possibility to apply a brake to the fan motor. This stops the motor immediately after the motor impulse has stopped and therefore improves the smoke effect.

The output is designed for a 5 V motor and up to 100 mA constant-current (the starting current can be much higher).

⚠ **Note:** Only available in the MX695KV, MX695LV, and other ..V- type models !

3.5 Servos

MX695 offers 4 connections for standard Servos, that can be used for de-couplers, pantos and other mechanical operations.

For each Servo connection there is a separate control wire available while the power (+ 5 V, Ground) is the same for all.

⚠ **ATTENTION:** Although different brands of Servos have the three wires, the order and color of the wires is not always the same.

See chapter dealing with decoder configurations regarding the order and adjustment of the Servos.

⚠ **Note:** 5 V supply for servos is only available in the MX695KV, MX695LV, and other V- type models!

The control wires are usable for all versions of the MX695, so you might have to supply +5 V external of the decoder.

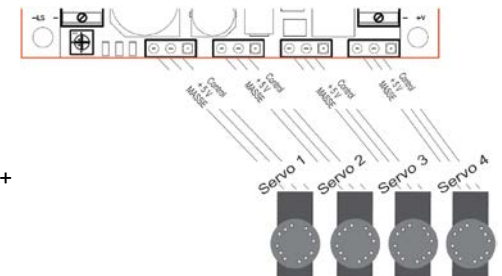

3.6 Control Input

In addition to "IN 3" (see chapter 3.2, Speakers and Cam Sensor) there are two more inputs ("IN 1" and "IN 2"). You can use for example reed contacts connected to these function inputs for generating sounds, e.g. bell and whistle. This is very desired for analog operations, but can be useful in DCC too, e.g. curve wheel squeal to be automatically triggered when the trains enters a curve.

These control inputs act electrically similar.

See chapter regarding decoder configuration (CV's), especially covering sound.

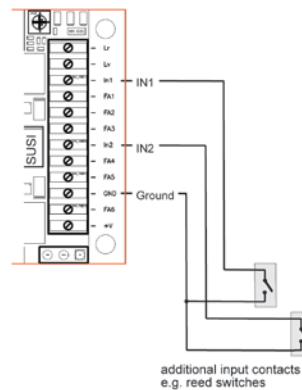

3.7 Electronic Flywheel

With the help of a capacitor (standard or Gold-Cap) or a re-chargeable battery you can:

- the driveability on dirty tracks (or with dirty wheels) is improved,
- the flashing of lights due to loss of contact (frogs, ...) is reduced,
- avoid that trains get stuck, while driving slow or on unpowered frogs, if used especially with the configuration feature "Prevention of stopping on current-less areas" *) which is available in all ZIMO decoders.
- the energy loss due to "RailCom-gaps" and "HLU-gaps" is compensated and the associated motor sounds are reduced. At the same time the RailCom signal quality (= readout quality) is improved.

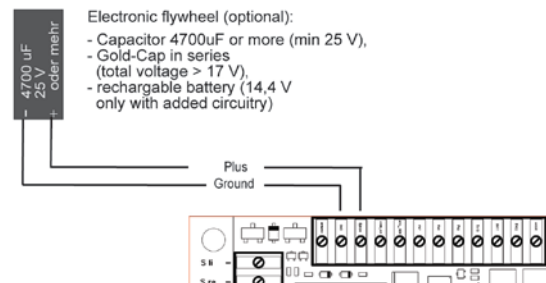

*) In case of loss of power (due to dirt on the tracks or on unpowered frogs) the decoder will automatically assure that the vehicle continues driving even if it is supposed to come to a halt due to a brake application. Only once the track power connection has been re-established will the train stop and check whether the connection is still present while stopped (otherwise a normal short advancement follows)

Generally the effectiveness of the electronic flywheel increases with the capacity; starting at approximately 1000 uF (uF = microFarad) an effect is noticeable, approximately 100,000 uF are advisable for large engines as long as the space is available; Gold-Cap arrangements with more F (Farad) are even better. Capacities that are too large, however, do have a drawback, the time for charging becomes very long. This is why ZIMO advises no more than 1 F for Gold-Caps (this is based on the overall series connection of 7 elements with 2.5 V each. A single Gold-cap has about 5F).

Charging current for external capacitor is approx. 80 mA; this means full charge of a 10,000 uF – capacitor is about 5 sec, in case of a 1 F Gold-Cap the charging time is ~ 3 min. Unlike a rechargeable battery (rechargeable), a capacitor only offers the maximum current once fully charged!

The MX695 has been developed that external capacitors DO NOT cause problems during decoder programming, and during software updates, and neither for the ZIMO train number identification or for RailCom.

The installation of a battery instead of a capacitor is currently only recommended for professionals (experienced electronic hobbyists); it is important that a total discharge is prevented after a loss of track power.



Suggestion: a relay with holding current supplied by track voltage, with holding capacitor, which disconnects the wires to the battery about 1 min. after loss of track power.

3.8 The SUSI Interface

The "SUSI" interface, developed by Dietz, defines the connection to additional modules, mostly sound, which is untypical when sound decoders are used.

Currently there are hardly any SUSI modules available except for the sound modules which are rarely used with a sound decoder such as the MX695.

On one hand the interface is designated as a reserve for possible pantograph circuit boards and similar equipment (possibly from ZIMO) and on the other hand ...

... for fast charging of sound projects (the way ZIMO has them factory-provided; in this case it is not about the SUSI protocol, but about the much faster communication)

See the chapter regarding decoder configuration (CV's), especially covering sound.

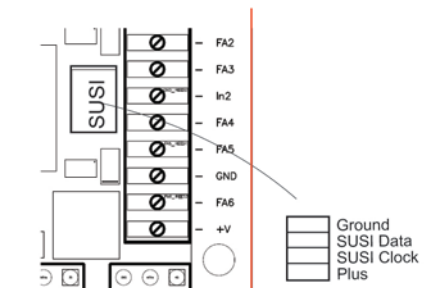

4 Configuration of the MX695 / (MX696) / (MX697)

ZIMO decoder can be programmed using

- **“Service mode”** (on the **programming track**) addressed (= registering the vehicle address) and programming (writing und read-out of the CV’s – configuration variables) or,
- **“Operational mode”** (“Programming-on-the-main” = “PoM”);
programming the CV’s in “operational mode” is always possible, the verification of the programming and the read-out ,however, only when the digital system understands **“RailCom”**.

4.1 Programming in “Service mode” (on the programming track)

In order to program, the programming block must be lifted, so

CV # 144 = 0 or = 128 (128: in this case programming is enabled, but SW updates are blocked)

CV # 144 = 0 is the decoders default, but some sound projects activate the programming block so that accidental changes are prohibited. Always check CV# 144 in particular if some programming attempts already failed.

The confirmation of programing steps as well as CV read-out are accomplished with power bursts. The decoder accomplishes this through a short activation of headlights and motor. Should there be no or too little current (e.g. they are disconnected) then the confirmation and the read-out are not possible.

In that case it might be possible to configure CV #112, Bit 1 to generate an alterntive method, the high feequency-impuls activation of the power circuit for the motor output. The success of this method depends on the central station in use.

CV	Designation	Range	Default	Description
# 144	Programming and Update Lock <small>Note: The program lock in CV # 144 has no influence for CV # 144 itself; otherwise it would be impossible to lift the lock.</small>	Bits 6, 7	0 or 255	= 0: Unrestricted CV programming, Bit 6 = 1: No programming possible in service mode: protection against unintentional programming. Note: “on-the-main” programming is still possible Bit 7 = 1: Software updates normally executed with the MX31ZL or future devices are blocked.
# 112	Special ZIMO configuration bits	0 - 255	4 = 00000100 also Bit 1 = 0 (normal)	Bit 1 = 0: Normal „service mode” acknowledgement by actuating motor and headlights. = 1: High frequency current impulses as additional acknowledgement, whenn motor/lights are not enough Bit 2 = 0: loco number recognition off etc,

4.2 Programming in “Operational mode” (on-the-main “PoM”)

Programming in “Operational mode”, otherwise known as “Programming-on-the-main” = PoM
“Programming-on-the-fly”.

According to the current NMRA-DCC standard, only CV-programming and read-outs are possible on the main track but not the ability to assign a new address. Specific command stations (such as ZIMO beginning with generation MX10/MX32) allow with “bi-directional communication” also the modification of the address.

All ZIMO decoders are equipped with bi-directional communication according to the **“RailCom”** operation, this way the usage of a corresponding central stations (ZIMO MX31ZL and all equipment starting with the MX 10/MX32 generation) and therefore confirm the completed programming as well as enable read-out fo CV valaues in “operational mode”, on the main track. For this “RailCom” must be activated. This is the case when,

CV # 29, Bit 3 = 1 AND CV # 28 = 3

Even though this is the factory setting, in some sound projects or OEM-CV-sets, however, this capability might be turned off and must be activated again.

CV	Designation	Range	Default	Description
# 28	RailCom Configuration	0 - 3	3	Bit 0 - RailCom Channel 1 (broadcast) 0 = off 1 = on Bit 1 - RailCom Channel 2 (Daten) 0 = aus 1 = eingeschaltet
# 29	Base Configuration <small>Configuration data</small>	0 - 63	14 = 0000 1110 also Bit 3 = 1 („RailCom” on)	Bit 0 – train direction 0 = normal, 1 = reversed Bit 1 - number of speed steps 0 = 14, 1 = 28 Fahrstufen Bit 2 - automatic detection of analog mode 0 = off, 1 = on Bit 3 - RailCom (“bi-directional communication”) 0 = off 1 = on Bit 4 – individual speed table 0 = three point-cl. according to CV # 2, 5, 6 1 = free characterisic according to CV # 67 ... 94 Bit 5 – Selection of vehicle address (DCC) 0 = primary address as per CV # 1 1 = ext. address as per CV's # 17+18



Note:
Greyed-out bits in the CV tables indicate capabilities that are not utilized in the given chapter.

4.3 Decoder-ID, Load-Code, Decoder-Type and SW-Version

CV	Designation	Range	Default	Description
# 250, 251, 252, 253	Decoder-ID includes also a code (in CV # 250) for the decoder-type	read only	-	The decoder ID (serial number) is automatically entered during production: the first byte denotes the decoder type; the three other bytes contain the serial number. The decoder ID will be required during registering at the central station as well as in combination with the load code for paid sound apps.(see CV's # 260 bis 263).
# 260, 261, 262, 263	Load-code for "paid-sound" apps	-	-	ZIMO sound decoders can be preinstalled with a load-code for an additional charge. Therefore they can accept a paid-sound app from one given provider. Otherwise the "load code" must be obtained and installed after purchase. See ZIMO's Website www.zimo.at or ZIRC.
# 8	Manufacturer ID and HARD RESET with CV # 8 = "8" bzw. CV # 8 = 0 or LOADING of special CV sets	Read only read-out always shows "145", which is ZIMO's assigned number Pseudo-Programm. see description on right	145 (= ZIMO)	Read-out of this CV is always the NMRA assigned manufacturer number; for ZIMO "145" ("10010001"). Additionally this CV is used during "pseudo-programming" to trigger reset operations. "Pseudo-programming" means: programmed value is not stored, instead the value triggers a definite action. CV # 8 = "8" → HARD RESET (NMRA-standardized); all CV's default back to the last CV-Sets used or (if none were previously activated) the default value, as described in this CV-chart. Further possibilities: see chapter "CV Sets" !
# 7	SW version number See also CV # 65 Sub-version number and Indirect Programming Temporary register when programming with a "Lokmaus-2" and similar low level systems	Read only Pseudo-Programm. see description on right	-	The read-out of this CV is the version number of the currently loaded decoder software (firmware). At the same time this CV is used via "pseudo programming" to program a decoder of a digital system with a limited handling capacity for higher numbers (typ. example: old Lokmaus): First digit = 1: subsequent program value + 100 = 2: ... + 200 Second digit = 1: subsequent CV-number + 100 = 2: ... + 200 cont. = 9: ... + 900 Third digit = 0: indirect programming for one operation = 1 ... until power down
# 65	SW Sub-version num. See also CV # 7 Version number	Read only	-	In case the version in CV # 7 is accompanied by a subversion, refer to CV # 65 The complete description of a software version is comprised of CV's # 7 + # 65 (for instance 28.15).

4.4 Engine address(es) in digital mode

The default setting for engine addresses is usually **Address 3**, meaning **CV # 1 = 3**, for the DCC mode as well as the MM mode. Operating on this address is possible but it is advisable to choose a new permanent address relatively quickly.

In the DCC mode the address space exceeds the range of a single CV, namely up to 10239. For addresses starting at 128, the two CV's # 17 + 18 are used. In CV #29, Bit 5 determines if the "short" address in CV # 1 is valid or the "long" address in CV's # 17 + 18 is used.



Modern digital systems (possibly with the exception of very old or simple products) execute the particular CV's and the Bit 5 in CV # 29 when writing the address (= addressing) to the decoder, and the user does not have to deal with the coding himself.

CV	Designation	Range	Default	Description
# 1	Primary "short" address	DCC: 1 - 127 MM: 1 - 80	3	The primary "short" address (DCC, MM) In DCC mode: According to CV # 1, the primary short address is only valid if CV # 29 (basic settings), Bit 5 = 0. Alternatively, the address according to CV # 17 + 18 is valid, so when CV # 29, Bit 5 = 1.
# 17 + 18	Extended Address	128 - 10239	0	The primary long address (DCC), when an address starting at 128 is chosen. The address according to CV's # 17 + 18 is valid when CV # 29 (basic setting), Bit 5 = 1.
# 29	Base Configuration	0 - 63	14 = 0000 1110 also Bit 5 = 0 ("short" address) 94	Bit 0 - Train direction: 0 = normal, 1 = reversed Bit 1 - Number of speed steps: 0 = 14, 1 = 28 speed steps Bit 2 - automatic detection of analog mode 0 = off, 1 = on Bit 3 - RailCom ("bi-directional communication") 0 = off, 1 = activated Bit 4 - Individual speed table 0 = three step prog. according to CV # 2, 5, 6 1 = free speed table according to CV # 67 ... Bit 5 - Selection of primary address (DCC) 0 = primary "short" address as per CV # 1 1 = ext. ("long") address as per CV's # 17+18

4.5 Decoder powered consist function (also: "advanced consist")

Consist operations means operating two or more vehicles (mostly mechanically coupled) with the same speed which can either

- be organized through the digital system (common in ZIMO, does not impact the decoder's CV's), or
- can be regulated by the following CV's of the decoder, which can be individually programmed, or handled by the central station (often found in American system).

This chapter only deals with the second case, the decoder controlled consist functions!

CV	Designation	Range	Default	Description
# 19	Consist address	0 - 127	0	Alternative addresses for the consist function, also referred to as traction function. If CV # 127 > 0: the speed is controlled via the consist address (and not via the single addresses in CV # 1 or # 17 + 18); these functions are selectively controlled via the consist address or the single address; see CV's # 19 + 20.
# 21	Consist Functions F1 - F8	0 - 255	0	Selection of the functions, which should operate with the consist address in the consist function. Bit 0 = 0: F1 operated via a single address = 1: via a consist address Bit 1 = 0: F2 operated via a single address = 1: via a consist address F3, F4, F5, F6, F7 Bit 7 = 0: F8 operated via a single address = 1: via a consist address
# 22	Functions F0 forward, backwards in consist operation Consist address active for FL	0 - 3	0	Select whether headlights are controlled via consist address or single address. Bit 0 = 0: F0 (forward) operated via a single address = 1: via a consist address Bit 1 = 0: F0 (backward) operated via a single address = 1: via a consist address

4.6 Analog mode

ZIMO decoders (all types) are very well suited for all conventional layouts (with model train transformers, PWM cruising equipment, etc.) as well as **analog continuous currents** and **analog alternating currents** (Märklin, also with high voltage pulse for direction reversal).

In order to enable the analog mode set:

CV # 29, Bit 2 = 1

Although this (CV # 29 = 14, also auch Bit 2 = 1) is a default setting, in some sound projects the analog mode has been deactivated. Therefore if the analog mode is not functioning it is useful to double check whether it was deactivated in the factory settings.

The new large scale decoders (MX695/6/7) are well suited for analog operation because they can start lights, sound and the motor at very low voltage enabled by "raising" the track voltage internally to a certain degree. See the chapter titled Technical Data. Stepped thresholds control that first only the headlights will work, then once more voltage is present the sound will start and finally the motor.

The actual performance in analog mode, however, is strongly dependent on the vehicle. If a weak transformer is used the track power can break down when the decoder begins the consumption of electricity and sufficient electricity is not available. If worst come to worst, it will oscillate between operating and not operating.

There are some programming possibilities for the motor control and function outputs in analog mode. The CV's can only be programmed or read in digital mode, with the help of a digital system or programming equipment.

CV	Designation	Range	Default	Description
# 13	Analog Functions F1-F8	0 - 255	0	Selects function outputs, F1 to F8, which should be "on" in analog mode. Each bit equals one function; Bit 0 = F1, Bit 1 = F2 Bit 6 = F7, Bit 7 = F8.
# 14	Analog functions and Regulated Analog	0 - 255	64	Bits 0 to 5: Choose function outputs F9 to F12 as well as HLr and HLf that should be "on" in analog mode. Each bit equals one function (Bit 0 = front headlight, Bit 1 = rear headlight, Bit 2 = F9...Bit 5 = F12). Bit 6 = 1: Analog operation without applying CV #3 and CV #4 defined momentum. Bit 6 = 0: Analog operation with CV #3 and CV #4 defined momentum. Bit 7 = 0: unregulated DC operation Bit 7 = 1: regulated DC operation
# 29	Base Functions F0 forward, backwards in consist operation Consist address active for FL	0 - 3	0	Bit 0 - Train direction: 0 = normal, 1 = reversed Bit 1 - Number of speed steps: 0 = 14, 1 = 28 speed steps Bit 2 - automatic detection of analog mode 0 = off, 1 = on Bit 3 - RailCom ("bi-directional communication") 0 = off, 1 = activated Bit 4 - Individual speed table 0 = three step prog. according to CV # 2, 5, 6 1 = free speed table according to CV # 67 ... 94 Bit 5 - Selection of primary address (DCC) 0 = primary "short" address as per CV # 1 1 = ext. ("long") address in CV's# 17+18



Note: Other settings, than the decoders default settings, can be active because of the currently loaded sound project. This is particularly true for the motor control settings that are often turned on by the sound project. Those configurations, however, only work well for controllers with a smooth output voltage (like LGB 50080). It is advisable to turn off motor control if you use half-wave track voltages.

4.7 Motor activation and motor control

The Speed Curve

There are two ways of programming the speed curve:

- CV # 29, Bit 4 = 0: three-step programming (defined by 3 CV's)
- ... = 1: 28-step programming (defined by 28 CV's)

Three-step programming: By using the three CV's # 2, 5, 6 (Vstart, Vhigh, Vmid) the starting speed, the highest speed and the middle speed can be defined. This offers a simple way to control the range and curvature of the speed curve. Usually the three-step programming is sufficient.

28 – step programming (also referred to as free programable speed curve): using CV's # 67 ... 94. All 28 external speed steps are attributed to their internal speed steps (0 – 255). These 28 CV's apply to all speed step systems, for all 14, 28, 128 speed steps; in the case of 128 speed steps, the decoder replaces all missing interim values through interpolation.

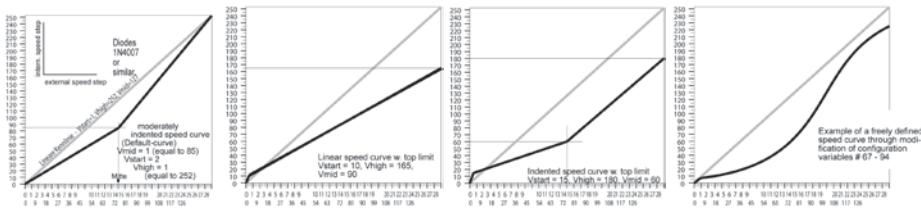

CV	Designation	Range	Default	Description
# 2	Vstart three Step programming, when CV # 29, Bit 4 = 0	1 - 255	1	Internal speed step (1 ... 255) for lowest external speed step (speed step 1) (regardless whether its 14, 28, or 128 speed steps) = 1: lowest possible starting speed
# 5	Vhigh three Step programming, when CV # 29, Bit 4 = 0	0 - 255	1 equivalent 255	Internal speed step (1 ... 128) for highest external speed step according to the highest number of speed steps selected, CV # 29, Bit 1 = 1: equates to 255, highest-possible speed
# 6	Vmid	1, ¼ to ½ of the value in CV # 5	1 (means approx. 1/3 of the maximum speed)	Internal speed step (1 ... 255) for mid external speed step (so for external speed step 7, 14 and 63 according to speed step system 14, 28, 128 laut CV # 29, Bit 1) "1" = default speed curve (mid speed is one third of the maximum speed, this means when CV # 5 = 255, then the speed mid point would be equal CV # 6 = 85). The three step speed curve generated from CV's # 2, 5, and 6 is automatically smoothed out so there are no bends in the curve.

CV	Designation	Range	Default	Description
# 29	Basic Configuration Configuration data	0 - 63	14 = 0000 1110 Bit 4 = 0 (three step speed curve)	Bit 0 – train direction 0 = normal, 1 = reversed Bit 1 - number of speed steps 0 = 14, 1 = 28/128 speed steps Bit 2 - automatic reversal to analog mode 0 = off, 1 = on Bit 3 - RailCom ("bi-directional communication") 0 = off 1 = on Bit 4 – Individual speed table 0 = three step prog. according to CV # 2, 5, 6 1 = speed step table according to CV # 67 ... 94 Bit 5 - Selection of primary address (DCC) 0 = primary "short" address as per CV # 1 1 = ext. ("long") address as per CV's # 17+18
# 67 # 94	Free (28-Step) Speed Curve when CV # 29, Bit 4 = 1	0 - 255	*)	Internal speed steps (respectively 1 ... 255) for each of the 28 external speed steps. *) The default-28-step-speed curve ist ebenfalls curved, with emphasis on the slow speed steps.
# 66 # 95	Directional SpeedTrimming	0 - 255 0 - 255	0 0	Multiplication of the current speed by "n/128" (n = trim value) Forward (CV # 66) or Backwards (# 95).

Reference Voltage for motor control

CV # 57 defines the desired voltage that is used to represent the absolute Maxspeed. For example, if 14V (so a value of "140") is selected, the decoder tries to regulate the exact fraction of the voltage level at the track. As a result the speed remains constant even if the track voltage fluctuates, provided the track voltage (more precisely, the rectified and processed voltage inside the decoder, which is about 2V lower) doesn't fall below this absolute reference voltage.

⚠ The default value "0" in CV# 57 indicates that "relative reference" is chosen. "Relative Reference" is only practical if the DCC system delivers stabilized output and the electric resistance along the track is kept small! All ZIMO systems (even older ones) have such a stabilized track voltage. Other external systems, especially relatively inexpensive ones that were built before 2005 do not have a stabilized track voltage. In those systems CV # 57 = 0 should not be used. Also . Large scale layout fair better with "Absolute Reference"

⚠ CV # 57 can also be used as an alternative to CV # 5 (maximum speed). The benefit is that all 256 internal speed steps are still available.

CV	Designation	Range	Default	Description
# 57	Voltage Reference	0 - 255	0	One tenth of the entered value is the peak voltage applied to the motor at full speed. Example: External system with 22V idle track voltage and under load of 16 V: The recommended value is CV # 57 = 140 ... 150 CV # 57 = 0: in this case automatic adjustment to the track voltage (relative reference) occurs; only sensible for stabilized track voltage.

Optimization of the Motor Control

The driving characteristics, especially at slow speeds (particular smooth homogenous operation) can be affected using the following CV's:

CV # 9 – Motor control frequency and EMF-Scanning rate:

The motor is controlled by pulse with modulation that can take place at either low or high frequency. The low frequency (30 to 159 Hz) is only necessary in a few very old motors (such as All-current types of permanent magnets). **High Frequency** (default, **20 kHz**, for example 40 kHz according to CV # 112) is silent and gentle on the motor.

Power to the motor, even when operated at high frequencies, is periodically interrupted (50 to 200 times/sec) in order to determine the current speed using back electromotive force (BEMF) measurements. The more often this interruption takes place (EMF sampling frequency), the better it is for the control, but this also results in an energie loss and increased noise. By default, the sampling frequency varies automatically between 200Hz (at low speeds) and 50Hz (at maximum speed)

CV # 9 offers the possibility to individually determine a value for the sampling frequency (ten's digit) as well as the length of the gap in measurement (one's digit); the default value 55 indicates a mid value.

CV # 56 – PID Control

Using *Proportional-Integral-Differential* values, the control mode for motor type, vehicle weight, etc. can be determined. In practice, there is limited value in configuring the differential value.

CV # 56 offers the possibility to individually determine the proportional value (ten's digit) as well as the integral value (one's digit). Default value 55 indicates a mid value, although a certain automatic justification occurs through the decoder software.

CV	Designation	Range	Default	Description
# 9	Motor ctrl frequency and EMF-Scanning rate- algorithm (scanning rate, time-out) Total PWM period	55 high fre- quency, mid scanning rate algo- rithm 01 - 99 high fre- quency with modefide EMF scanning rate algo- rithm	55 high fre- quency, mid scanning rate algo- rithm	= 55 : default motor control with high frequency (20/40 kHz), mid scanning rate of the motor EMF measurement that automatically varies from 200 Hz (low speeds) to 50 Hz and mid EMF time-out. <> 55 : modification of the automatic optimization with separate settings for the sampling rate (ten's digit) and time out (one's place). Ten's Digit 1 - 4: Reduced sampling rate compared to default (less noise!) Ten's Digit 6 - 9: Increased sampling rate compared to default (to improve low speed performance) One's Digit 1 - 4: EMF time-out is shorter than default (good for Faulhaber, Maxxon, .. less engine noise, more output) One's Digit 5 - 9: EMF time-out is longer than default (possibly needed for 3-pole-motor or similar) Typical test runs when experiencing rough driving:
# 9	<i>Continued:</i>			

	Motor ctrl frequency and EMF-Scanning rate-	255-176 low fre- quency		CV # 9 = 55 (default) → 83, 85, 87, ... CV # 9 = 55 (default) → 44, 33, 22, ... = 255 - 178: low frequency (only for old motors !) – PWM according to formula (131+ mantissa*4) *2exp. Bit 0-4 is "mantissa"; Bit 5-7 is "exp". Motor frequency is the reciprocal of the PWM. Examples: CV # 9 = 255: motor frequency 30 Hz, CV # 9 = 208: motor frequency 80 Hz, CV # 9 = 192: motor frequency 120 Hz.
# 112	Special ZIMO Configuration bits	0 - 255	4 = 00000100 Bit 5 = 0 (20 kHz)	Bit 1 = 0: normal acknowledgement. = 1: high frequency-high current impulses Bit 2 = 0: loco number pulses off = 1: ZIMO loco number pulses on Bit 3 = 0: 12-function-mode = 1: 8-function-mode Bit 4 = 0: pulse chain recognition off = 1: pulse chain recognition (for old LGB systems) Bit 5 = 0: motor control frequency with 20 kHz = 1: ... with 40 kHz Bit 6 = 0: normal (also see CV # 29) = 1: "Märklin brake mode"
# 56	P- and I- Value for the EMF-Load balancing scheme	55 medium PID setting 01 - 199 modified setting	55	= 55: default motor control using medium PID parameters. = 0 - 99: modified settings for "normal" motors (e.g. Bühler, etc.) = 100 - 199: modified settings for brushless motors (e.g. Faulhaber, Maxon, etc.) Ten's Digit 1 - 4: Reduced proportional value of the PID control compared to default Ten's Digit 6 - 9: Increased proportional value of the PID control compared to default. One's Digit 1 - 4: Reduced integral value of the PID control compared to default setting One's Digit 6 - 9: Increased integral value of the PID control compared to default setting Typical test runs when experiencing rough driving: CV # 56 = 55 (default) → 33, 77, 73, 71, ..

Suggestions for Optimization (in case default settings are not sufficient):

Vehicle, motor type	CV # 9	CV # 56	Remarks
LGB-Loco with Bühler-motor(s)	(55)	(55)	The default settings are usually sufficient for the vehicle performance.
Loco with Faulhaber motor (Maxon)	12	111	Relatively rare and short time-outs, "gentle" readjustment, special Fauhaber procedure, quiet!
Märklin Track 1 (such as V100)	65	12	Slightly above average time-outs, but also "gentle" readjustment.
PIKO VT98 (easy construction)	91	91	High sample rate (but short time-outs), high P-value (but not I-value).
PIKO Taurus (relatively difficult)	64	63	Marginally higher sample rate and P-value (between LGB and PIKO VT98).
DEMKO Herkules, Track 0	71	141	Higher sample rate, otherwise typical of Faulhaber.

A suggestion in finding the optimal setting for CV # 56:



Output setting CV # 56 = 11; Drive slowly and restrain the engine with your hand. Within half a second, the controller should readjust. If it takes longer, gradually adjust the ones's digit: CV # 56 = 12, 13, 14, ...

Continue to drive slowly and gradually increase the ten's digit for CV # 56, for instance (if CV # 56 = 13 was determined) CV # 56 = 23, 33, 43, As soon as the driving conditions worsen, revert to the previous setting → this is then the correct setting.

Load Compensation – Reduction and Standard-Curve

Although the goal of load compensation is to keep the speed constant in any circumstance (only limited by available power), often times a certain reduction in compensation is preferred.

Usually 100% load compensation is useful during low speeds to successfully prevent engines from stalling or "run-away" acceleration with low loads. BEMF should be reduced as the speed increases so that the motor receives full power with little BEMF. Also the speed in dependency of the layout course is highly desirable and leads to a prototypically correct appearance.

During consists operations (several engines connected together) the load compensation should not be at 100% as it would cause the individual engines to work against each other and possibly lead to derailment.

Using CV #58 the degree of load compensation can be set from "no regulation" (value 0, decoder acts like an unregulated decoder) to "full regulation" (value 255); typically useful values range from 100 to 200.

In case a more precise control of the load compensation is desired, or a more complete control of the entire range, a three point curve can be generated with CV's # 10 and # 113.

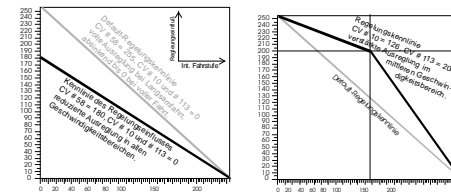

CV	Designation	Range	Default	Description
# 58	Back EMF intensity	0 - 255	255	Intensity of back-EMF for lowest speed step. If required, an "regulation curve" can be set using CV # 10 and CV # 113 to reduce load regulation at higher speeds. These three CVs (# 58, # 10, # 113) can be used as three step programming. EXAMPLES: CV # 58 = 0: no back-EMF CV # 58 = 150: medium compensation CV # 58 = 255: maximum compensation
# 10	EMF Feedback Cutoff <small>This CV is seldom used</small>	0 - 252	0	Assigns an internal speed step above which back EMF intensity is reduced to the level defined in CV # 113. CV's #10, #58, and #113 together define a back-EMF curve. If either CV #10 or #113 is set to 0 a default curve is valid.
# 113	BEMF reduction <small>This CV is seldom used</small>	0 - 255	0	Intensity of back-EMF is reduced above the speed step defined in CV #10, to the value entered here. Together, CV #10, #58 and #113 define a BEMF curve. If set to 0, BEMF is totally cut-off above the speed step defined in CV #10.

The Motor Brake

The motor brake is necessary in vehicles without worm gears to prevent rolling away and driving too fast on declining tracks, or being pushed by another train.

CV	Bezeichnung	Bereich	Default	Beschreibung
# 151	motor brake	0 - 9	0	= 0: no motor brake = 1 ... 8: The motor brake is gradually actuated when the target speed 0 is reached during breaking (reaches full breaking over 1,2 ...8 seconds by applying both motor end stages). = 9: Applies full motor brake immediately when speed 0 is reached by applying both motor end stages. The higher the value, the faster and stronger the motor brake initiates.

4.8 Acceleration and Deceleration:

The basic settings for the acceleration and deceleration rates are achieved using

CV's # 3 und # 4

In accordance to NMRA standards. The speed is changed in equal time intervals from one speed step to the next.

To achieve smooth driving conditions, values starting at "3" are recommended. "True" slow starts and stops begin at about "5". Values over "30" are rarely practical!



Sound decoders always contain one sound project which determines the actual default value for CV's #3 and #4 (as well as many other CV's); other than the given values of the CV chart. Since often times the sound can only be determined correctly along with the acceleration performance in a sound projects particular range, the predetermined values should not be altered too drastically.

Through "exponential starting/braking" as well as through "adaptive acceleration and deceleration" (CV's #121, #122, #123) can the acceleration and deceleration operations be improved, particularly the starting and stopping.

CV #146 can be used to eliminate jerky starts after a change in direction (caused by the neutral gear). The transmission of energy between the motor and the wheels usually points to a neutral gear, especially when dealing with a worm gear. This causes the motor to run for a bit before powering the wheels during a change in direction. During this phase the motor is already accelerating so when it starts to power the wheels and drive it already has a higher speed which causes a jerky start motion. This can be avoided if the acceleration is suppressed for a specific amount of time; this can be set using CV #146.

CV	Designation	Range	Default	Description
# 3	Acceleration Rate	0 - 255	(2)	The content of this CV multiplied by 0.9 equals the time in seconds required to go from a complete stop to full speed. The actual effective default value is usually not the value given here, but is instead determined by the loaded sound project.
# 4	Deceleration Rate	0 - 255	(1)	The content of this CV multiplied by 0.9 equals the time in seconds required to go from full speed to a complete stop. The actual effective default value is usually not the value given here, but is instead determined by the loaded sound project.
# 121	Exponential Acceleration	0 - 99	0	Acceleration time (momentum) can be stretched in the lower speed range: Ten's place: % of speed range to be included (0 to 90). One's place: Exponential curve (0 to 9). Example: CV # 121 = 11, 23, 25, ...
# 122	Exponential Deceleration	0 - 99	0	Deceleration time (momentum) can be stretched in the lower speed range: Ten's place: % of speed range to be included (0 to 90)

CV	Designation	Range	Default	Description
				One's Place: Exponential curve (0 to 9). Typically used with the same values as CV #121.
# 123	Adaptive Acceleration and Deceleration	0 - 99	0	Raising or lowering the speed to the next internal step occurs only if the preceding step is nearly reached. The tolerance for reaching the preceding step can be defined by this CV (the smaller this value the smoother the acceleration/deceleration) Value = 0: no adaptive acceleration or deceleration Ten's digit: 0 - 9 for acceleration One's digit: 0 - 9 for deceleration = 11: strongest effect; sometimes makes the start impossible (engine can't move)
# 146	Compensation for gear backlash during direction changes in order to reduce start-up jolts	0 - 255	0	= 0: no effect = 1 bis 255: the motor spins at minimum rpm (according to CV #2) for a specific time. Acceleration starts after that time has elapsed. This only happens when a direction change has been performed! How much time is required to overcome the backlash depends on various circumstances and can only be determined by trial and error. Typical values are: = 100: the motor turns about 1 revolution or a maximum of 1 second at the minimum speed. = 50: approximately ½ a turn or max. ½ second = 200: approximately 2 a turns or max. 2 seconds Important: CV #2 (minimum speed) has to be set correctly, that is the engine has to move at the lowest speed step (1 of 128 or 1 of 28). Also, CV #146 is only useful if the load regulation is set to maximum or at least close to it (i.e. CV #58 = 200 - 255)



Note: The actual acceleration and deceleration rate in the case of HLU-brake-tracks (ZIMO "signal dependent" automatic train control) is determined by CV's # 49, # 50.



To better understand the acceleration behavior :

The acceleration and deceleration behavior according to CV #3 and #4, meaning the timely progression of speed steps, is based on the 255 internal speed steps which are spaced equidistant from 0 to full speed. The active speed table (three-step or 28-step) does not influence the acceleration behavior.

This means that the acceleration sequence CAN NOT be improved through a bent speed curve. Exponential acceleration, CV's #121 and #122, however, can improve the acceleration behavior.

4.9 Special Mode of Operation “km/h – speed regulation”

The km/h – speed regulation is an alternative method of driving with prototypical speeds in all modes of operations: the speed steps of the controller or the throttle (1 to 126 in the 128 speed step configuration) are directly interpreted as km/h values.

The ZIMO decoder do not maintain prototypical speeds by calculating speed steps into speeds, but by recalculating the already traveled distance and automatically readjusts itself accordingly.

A CALIBRATION RUN should be performed with each loco:

First the calibration track needs to be determined: a section of track that measures 100 scale meters (including the necessary distance to allow for acceleration and deceleration) without any inclines, tight curves or other obstacles. For example: for G-scale (1:22.5) 14.75' (4.5m), US G-scale (1:29) 11.5' (3.5m). Start and end points on the calibration track should be visibly marked.

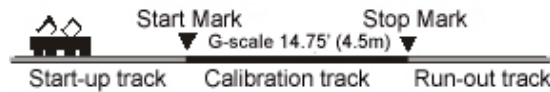

- Step 1. Place loco on the track 3' to 6' before the start point, select proper travel direction, function F) (headlights) turned off. Acceleration times (as well as CV #3 in the decoder and the throttle) should be set to a 0 or small value.
- Step 2. The calibration mode is activated by programming (in operational mode) CV #135 = 1. This is pseudo-programming since the value 1 is not saved, the previous value in CV #125 is retained.
- Step 3. Select a medium running speed with the speed regulator (1/3 to 1/2 of full speed); the loco drives towards the start point at that speed.
- Step 4. When the engine passes the start point, use the throttle to turn on function F0 (headlights); turn F0 off again when passing the end point. This completes the calibration run and the loco may be stopped.
- Step 5. As a control, CV #136 can now be read. The given calibration result by itself does not indicate much. If however, several calibration runs have been performed in a row, then the value shown in CV #136 should be about the same every time, even if the traveling speed is varied.

Km/h Speed Regulation in Operation:

CV # 135 controls the selection between “normal” or km/h operation:

CV # 135 = 0: The engine is controlled in “normal” mode; a possible km/h calibration run performed earlier has no effect but the calibration results remain stored in CV #136.

CV # 135 = 10 or 20 or 5: each external speed step (1 bis 126) means
 1 km/h or 2 km/h or 1/2 km/h: also see CV-chart below!

The speed regulation in km/h is not just useful for direct throttle control, but also in speed limits through the “signal controlled speed influence” (CV's 51 – 55). The values entered to those CV's are also being interpreted in km/h.

CV	Designation	Range	Default	Description
# 135	km/h –speed regulation activating, control and range definition	2 - 20	0	= 0: km/h – regulation turned off; the “normal” speed regulation is in effect. “Pseudo-Programming” („Pseudo“ = programmed value is not being stored): = 1 → Initiates a calibration run (see ch. 4, “km/h – speed control”) “Normal” Programming: = 10: each step (1 to 126) represents 1 km/h; so step 1 = 1 km/h, step 2 = 2 km/h, ... = 20: each step represents 2 km/h; so step 1 = 2 km/h, step 2 = 4 km/h, ... 252 km/h = 5: each step represents 0,5 km/h; so step 1 = 0,5 km/h, step 2 = 1 km/h, .. 63 km/h
# 136	km/h –speed regulation or control number read-out	Calibration run or RailCOM read-out factor	Auslesewert 128	A numeric value can be read here after a successful calibration run, which is used to internally calculate the traveling speed. This value should remain unchanged (only slightly changed) during several calibration runs. or Correction factor for the speed feedback using RailCom or another procedure of “bi-directional communication”.



Mph (miles per hour) instead of km/h:

Mph speed adjustment is achieved by extending the calibration distance accordingly

4.10 ZIMO “signal controlled speed influence” (HLU)

ZIMO digital systems offer a second level of communication for transmitting data from track segments to engines that are currently on those sections. The most important application for this is the “signal controlled speed influence”, which includes the stopping of trains and applying speed limits in 5 stages all of which is communicated via ZIMO's track section modules MX9 (or successor) to the track segments..

If the “signal controlled speed influence” is being used (only possible within a ZIMO system), the speed limits “U” and “L” (and the intermediate steps if needed) can be set with configuration variables CV's #51 to #55 as well as acceleration and deceleration values (momentum) with CV #49 and #50.

Please note that the signal controlled acceleration and deceleration times are always added to the times and curves programmed to CV #3, 4, 121, 122 etc. Signal controlled accelerations and decelerations compared to cab controlled momentum can therefore progress either at the same rate (if CV #49 and #50 is not used) or slower (if CV #49 and/or #50 contain a value of >0), but never faster.

In order to have a properly functioning train control system using the signal controlled speed influence, it is important that all tracks are laid out correctly, especially the stopping and pre-braking/deceleration sections of the track. Please consult the MX9 instruction manual.

The settings for the loco's braking characteristics should be set up in such a way (for deceleration CV #4 and CV #50 and for the speed limits CV #52 for "U") that each loco comes to a complete stop after about 2/3 of the length of the stopping section (For G, typically 2' 2 1/2' [70cm-80 cm] before the end). Setting the loco up to stop precisely with in the last inches of a stopping section is not recommended.

CV	Designation	Range	Default	Description
# 49	Signal controlled (HLU) acceleration	0 - 255	0	Entered value multiplied by .4 equals acceleration time in seconds from stop to full speed when: "ZIMO signal controlled speed influence" (with ZIMO MX9 track section module or successor) or "asymmetrical DCC signal" method (Lenz ABC) is employed
# 50	Signal controlled (HLU) deceleration	0 - 255	0	Entered value multiplied by .4 equals acceleration time in seconds from full speed to complete stop when: "ZIMO signal controlled speed influence" (with ZIMO MX9 track section module or successor) or "asymmetrical DCC signal" method (Lenz ABC) is employed
# 51 # 52 # 53 # 54 # 55	Signal dependent (HLU) speed limits # 52 for "U", # 54 for "L", # 51, 53, 55 for intermediate steps	0 - 255	20 40 (U) 70 110 (L) 180	ZIMO "signal controlled speed influence" method (HLU) using MX9 or successor: Defines the internal speed steps for each of the 5 speed limits generated via HKU.
# 59	Signal dependent reaction time	0 - 255	5	"ZIMO signal controlled speed influence" (requires ZIMO MX9 or successor) or "asymmetrical DCC signal" method (Lenz ABC): This value multiplied by 10 is the time in seconds it takes to start a signal controlled acceleration after receiving a higher speed limi.

4.11 Signal Control using "asymmetrical DCC-Signal" (Lenz ABC)

The "asymmetrical DCC signal" is an alternative method for stopping trains for example at a "red" signal. All that is required is a simple circuit made up of 4 or 5 commercially available diodes.

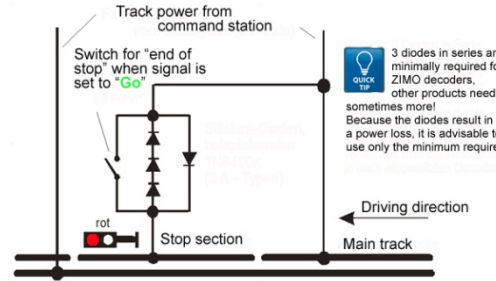

Usually 3 - 5 Silizium diodes in series and one Schottky diode parallel in opposite direction is how the stopping section is initiated. The varying voltage drop generates an asymmetry from approximately 1 to 2 V. The mounting direction determines the polarity of the asymmetry and with it the driving direction in which the stop signal shall occur.

The asymmetrical DCC signal stop mode needs to be activated with CV #27 in the decoder with setting bit 0. This means CV #27 = 1, which results in the same direc-

tional control as the "Gold" decoder from Lenz.

The asymmetrical threshold (default = .4V) can be modified with CV #134 if necessary. This might be needed if the digital system already has an asymmetrical signal. Todate, the "asymmetrical DCC signal" has not been standardized and many DCC systems pay no attention to this feature!



NOTE: ZIMO decoders do not support the usual ABC slow speed step present in decoders by Fa. Lenz (used in Lenz-Module BM2 for instance).

CV	Designation	Range	Default	Description
# 27	Position dependent stops ("infront of red signal") through asymmetrical DCC signal (ABC)	0, 1, 2, 3	0	Bit 0 = 1: stops are initiated when voltage in right rail (in direction of travel) is higher than in left rail. CV # 27 = 1 IS THE COMMON SETTING. (provided the decoder has been connected correctly). Bit 1 = 1: stops are initiated when voltage in left rail is higher than in right rail (in direction of travel). Stopping is directional if only one of the two bits is set (not both). Traveling in the opposite direction will have no effect. Use the other bit in case the train stops in the wrong direction. Bit 0 and Bit 1 = 1 (also CV # 27 = 3): stops are initiated regardless of the direction of travel during asymmetry.
# 134	Asymmetrical threshold for stopping with asymmetrical DCC signal	1 - 14, 101 - 114, 201 - 214	106	Hundredths digit: Sensitivity adjustment, changes the speed with which the asymmetry is being recognized. = 0: fast recognition (but higher risk of errors, i.e. unreliable stopping).

CV	Designation	Range	Default	Description
#134	continued (Lenz ABC method)	= 0,1 - 1,4 V		= 1: normal recognition (approx. 0.5 sec), fairly reliable (default). = 2: slow recognition (approx. 1 sec), very reliable Tenths and ones digit: Asymmetrical threshold in tenths of a volt. The voltage difference between the half waves of the DCC signal is the minimum required to be recognized as asymmetrical that starts the intended effect (usually braking and stopping of a train). = 106 (Default) therefore means 0.6 V. This value has proven itself to be appropriate under normal conditions; by using 4 diodes to generate the asymmetry.
# 142	Distance controlled stopping (constant stopping distance) Asymmetric DCC - Signal	0 - 255	12	The delayed recognition (see CV #134) but also unreliable electrical contact between rails and wheels has a larger effect at higher speeds on a stop point than at lower speeds. This effect can be corrected with CV #142. = 12: Default. This setting usually works fine if CV #134 is set to default

4.12 DC Brake Sections (Märklin brake-mode)

These are the "classic" methods of the automatic train controls. For example, stopping at a red signal. The required settings for the ZIMO decoder are spread over several CV's.

CV	Designation	Range	Default	Description
# 29, # 124, # 112	in these CV's are individual bits responsible for the correct reaction to DC and Märklin-brake sections	-	-	During utilization of DC brake sections dependent on polarity, the following inputs should be made CV # 29, Bit 2 = 0 and CV # 124, Bit 5 = 1 During utilization of Märklin brake sections independent of polarity, the following inputs should be given CV # 29, Bit 2 = 0 und CV # 124, Bit 5 = 1 und zusätzlich CV # 112, Bit 6 = 1

4.13 Distance Controlled Stopping - Constant Stopping Distance

If CV # 140 (= 1, 2, 3, 11, 12, 13) was used to choose a constant stopping distance, then deceleration to the point of a complete stop follows this procedure, where as in

CV # 141

the defined distance to the end point id relatively unaltered, independent of the previous speed at the beginning of the deceleration (inlet velocity).

This method is especially suitable in connection with automated stops in front of a red signal with the help of the **ZIMO HLU** signal controlled speed influence or the **Lenz ABC** asymmetrical DCC-signal (see above). CV #140 is set for this purpose to 1 or 11.

Although of lesser practical value, the distance controlled stopping can also be activated directly by the throttle or computer when the speed is set to 0 (by programming CV #140 with appropriate values of 2, 3, 12, or 13).

CV	Designation	Range	Default	Description
# 140	Distance controlled stopping (constant stopping distance) Select start of braking and braking process	0 - 255	0	Activates distance controlled stopping as per CV #141 in place of time-constant braking according to CV #4. = 1 automatic stops with signal controlled speed influence or asymmetrical DCC signal = 2 manual stops using the cab. = 3 automatic <u>and</u> manual stops. If the train travels at less than full speed the start of braking is delayed in above cases (= 1, 2, 3), to prevent an unnecessary long "creeping" (recommended). On the other hand: = 11, 12, 13: selection like above, but braking starts always immediately after entering the brake section.
# 141	Distance controlled stopping (constant stopping distance) Setting the distance	0 - 255	0	This CV defines the "constant stopping" distance. The right value for the existing stop sections has to be determined by trial. Use these figures as a starting point: CV #141 = 255 is about 500m (8' in G), CV #141 = 50 about 100m (1.5' in G)
# 142	High-speed compensation using Asymmetrical DCC - Signal	0 - 255	12	The delayed recognition (see CV #134) but also unreliable electrical contact between rails and wheels has a larger effect on a stop point at higher speeds than at lower speeds. This effect is corrected with CV #142. = 12: Default. This setting usually works fine if CV #134 is set to default
# 143	... compensation using the HLU method	0 - 255	0	Since the HLU method is more reliable than the ABC method, no recognition delay is usually required in CV #134; therefore this CV can also remain at default setting 0

The distance controlled stopping can take place in two possible order of events; see diagram above: The first is the recommended method (CV #140 = 1, 2, 3), where the train is entering at lower speeds, and continues to run at first at the same speed before it starts braking (with a "normal" deceleration rate, same rate as would be applied at full speed).

In the second method (CV #140 = 11, 12, 13.), however, the train starts immediately with the braking procedure, which may lead to an un-prototypical behavior. It may however be useful to use this method if used together with decoders from other manufacturers that do not have this capability in order to harmonize the brake sequences.

Also, the second method may be the preferred method if distance controlled stopping is used manually (CV #140 = 12), so that the train reacts immediately to speed changes

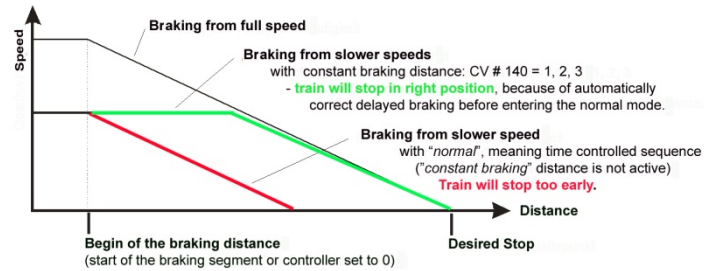

First method for a constant stopping distance

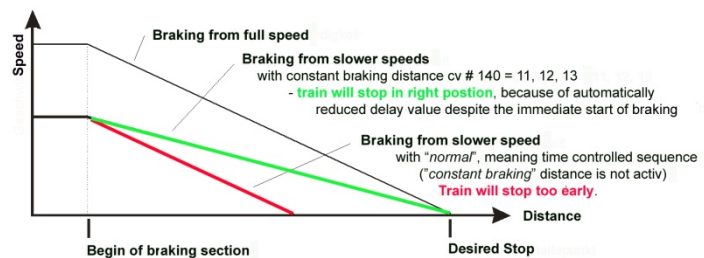

Second method for a constant stopping distance



"Distance controlled stopping", when activated, is exclusively applied to **decelerations leading to a full stop**. Reductions in speed or acceleration events are not affected by this (still handled by CV #3, #4, etc.)

The traveled distance is constantly being recalculated in order to get as close as possible to the desired stop point. The deceleration rate within distance controlled stopping is always applied exponentially, that is the deceleration rate is high in the top speed range followed by gentle braking until the train comes to a full stop; which is NOT controlled by CV #122! The application of CV #121 for exponential acceleration however remains unchanged.

4.14 Shunting and Half-Speed, MAN-Functions:

Using the different configuration variables (#3, 4, 121, 122, 123) to set the acceleration and deceleration behavior, offers on one hand prototypical operation, but on the other, it is often less ideal for quick and easy shunting.

With the help of CV #124, the MAN key (only on Zimo cabs, for other cabs F4 or F3 key can be assigned as a shunting key) with which the acceleration and deceleration rates may be reduced or eliminated all together.

For historical reasons, the attributes assigned to the shunting key functions are consolidated in CV # 124. However, they are somewhat limited as well as unclear.

Looking at it today, the settings as per CV's 155, 156, 157, are preferable. For each shunting key as well as MAN key one can systematically and without limitations choose a function key. Concerning the momentum time reduction, however, CV #124 is still relevant.

CV	Designation	Range	Default	Description
# 124	<p>Shunting key functions:</p> <p>Low gear and Momentum reduction or deactivation</p> <p>NOTE: Further selection for shunting keys in CV's # 155, 156</p> <p>Bit 5 DC stopping</p>	Bits 0 - 4, 6	0	<p>Select shunting key for LOW GEAR ACTIVATION: Bit 4 = 1 (and Bit 3 = 0): F3 as half speed key Bit 3 = 1 (and Bit 4 = 0): F7 as half speed key</p> <p>Select shunting key for MOMENTUM DEACTIVATION: Bit 2 = 0 (and Bit 6 = 0): MN-Key for shunting Bit 2 = 1 (and Bit 6 = 0): F4 key for shunting Bit 6 = 1 (Bit 2 is irrelevant): F3 as shunting key</p> <p>Effect of above key (MN, F3 or F4) on MOMENTUM: Bits 1,0 = 00: no effect with above key's = 01: removes momentum of CV #121 + #122 = 10: CV #3 + #4 reduced to ¼. = 11: removes all momentum above.</p> <p>Bit 5 = 1: "DC stopping", see CV #2</p> <p>EXAMPLES: F3 for shunting key: CV #124 = 16 F3 for shunting key and F4 to remove momentum completely: Bits 0, 1, 2, 4 = 1, so CV # 124 = 23. F3 for half-speed key and removing momentum: Bits 0, 1, 4, 6 = 1, so CV # 124 = 83</p> <p>Bit 5 = 1: "Gleichstrom-Halteabschnitte".</p>
# 155	<p>Selection of a function key for Half speed</p>	0 - 19	0	<p>Used in an extension to the adjustments in CV #124, if ist selection (half-speed on F3 or F7) is not sufficient, e.g because a different key is desired:</p> <p>CV # 155: Defines the function key for activating half-speed (= highest speed step results in half-speed).</p> <p>If CV # 155 > 0 (meanign a function key is assigned), a potential assignment with CV # 124 is ignored.. CV # 155 = 0" doesn't point to F0, but means that CV # 124 configuration is active.</p>

# 156 continued Selects a function key for deactivation of the acceleration and deceleration times	0 - 19	0	<p>In addition to the adjustment in CV # 124, if the selction (deactivation on F3, F4 or MAN) is not sufficient (other keys):</p> <p>CV # 155: Definition of the function key that deactivates or reduces the acceleration and deceleration times defined in CV's 3, 4, 121, 122.</p> <p>The adjustments in CV # 124 defining the type of deactivation or reduction are in effect as well:</p> <p>CV # 124, Bit 1, 0: = 00: no influence for acceleration = 01: key deactivates Exponential + Adaptiv. = 10: reduces acceleration/deceleration to ¼ of the valaues in CV's # 3,4. = 11: deactivates acceleration and deceleration compeltely</p> <p>Typically you configure CV # 124 = 3, in order to deactivate acceleration/decelertation completely. (unless other Bits in CV # 124 are set as well).</p> <p>If CV #156>0 (a key is assigned) then the key assignment for acceleration and deceleration in CV # 124 is ignored.</p>
# 157	Selects a function key for the MAN function Only needed for application where the Zimo MN key is not available.	0 - 19	0	<p>The MAN-function (respectively the MAN-key in the ZIMO handheld) was originally only for ZIMO applications designed, in order to eliminate the stop and speed settings within the HLU-syستم (signal depending train control).</p> <p>Later software version offered these functionalities also for stop at signal initiated through „asymmetrical DCC-Signal“ (Lenz ABC), which means that the MAN key can also suspend the stopping.</p> <p>In the case that ZIMO decoders are used with non ZIMO system CV #157 can now assing any function key to suspend the automated train control or the signal stop This will be more likely for ABC applications than HLU applications.</p>

4.15 Function Mapping as per NMRA-DCC-Standard

ZIMO large scale train decoders have 8 or 14 function outputs (FO). The loads connected to these outputs (head lights, smoke generators, etc.) are turned on or off using the function keys or throttle. Which key controls which function can be specified by a series of configuration variables.

The configuration variables, CV's # 33 bis # 46 form the NMRA function map according to their rules and regulations, which at the same time also restricts free allocation (each function only has an 8-bit register, meaning only 8 outputs available) and only the headlight function is intended for directional control.

Function key	Numerical Key on ZIMO throttle	CV	Additional Function Outputs for Models MX695KV, MX695LV							Function Outputs of all MX695 Models						
			FO12	FO11	FO10	FO9	FO8	FO7	FO6	FO5	FO4	FO3	FO2	FO1	rear light	front light
F0	1 (L) forward	# 33							7	6	5	4	3	2	1	0●
F0	1 (L) reverse	# 34							7	6	5	4	3	2	1●	0
F1	2	# 35							7	6	5	4	3	2●	1	0
F2	3	# 36							7	6	5	4	3●	2	1	0
F3	4	# 37				7	6	5	4	3	2	1●	0			
F4	5	# 38				7	6	5	4	3	2●	1	0			
F5	6	# 39				7	6	5	4	3●	2	1	0			
F6	7	# 40				7	6	5	4●	3	2	1	0			
F7	8	# 41	7	6	5	4	3	2●	1	0						
F8	9	# 42	7	6	5	4	3●	2	1	0						
F9	0	# 43	7	6	5	4●	3	2	1	0						
F10	↑1	# 44	7	6	5●	4	3	2	1	0						
F11	↑2	# 45	7	6●	5	4	3	2	1	0						
F12	↑3	# 46	7●	6	5	4	3	2	1	0						

The above chart shows the default settings marked; this means during outputs, the F-number corresponds to the FO-number. Therefore the following values were written to the configuration variables:

- CV # 33 = 1
- CV # 34 = 2
- CV # 35 = 4
- CV # 36 = 8
- CV # 37 = 2
- CV # 38 = 4
- CV # 39 = 8
- CV # 40 = 16
- CV # 41 = 4
- etc.



Example for modification of the function mapping: The function key F2 (ZIMO key 3) shall control the function outputs FO2 as well as FO4. In addition F3 and F4 shall not initiated the outputs FO3 and FO4, but instead the putputs FO7 and FO8 (e.g. for controlling couplers). Therefore new vlaues have to be configured into the appropriate CV values:

- CV # 36=40
- CV # 37 = 32
- CV # 38 = 64

F2	3	# 36							7	6	5●	4	3●	2	1	0
F3	4	# 37			7	6	5●	4	3	2	1	0				
F4	5	# 38			7	6●	5	4	3	2	1	0				

4.16 The extended ZIMO Function mapping

The original NMRA Function mapping offers only limited configuration, therefore ZIMO decoders offer an extended form which is described on the following pages. Most of the options work based with the special ZIMO

CV # 61

Therefore CV # 61 = 97 activates the alternative „function mapping“ without left shifting. With CV # 61 = 97 the left shifted configuration of the higher CV (from #37 according to NMRA mapping) are cancelled. Therefore higher functions can access lower functions as well.: e.g. „F4 can control FO1“ which is not possible according to NMRA, but via ZIMO.

FO6 FO5 FO4 FO3 FO2 FO1 head rear front

Function	CV	FO6	FO5	FO4	FO3	FO2	FO1	head rear	front
F0	1 (L) vr # 33	7	6	5	4	3	2	1	0
F0	1 (L) rü # 34	7	6	5	4	3	2	1	0
F1	2 # 35	7	6	5	4	3	2	1	0
F2	3 # 36	7	6	5	4	3	2	1	0
F3	4 # 37	7	6	5	4	3	2	1	0
F4	5 # 38	7	6	5	4	3	2	1	0
F5	6 # 39	7	6	5	4	3	2	1	0
F6	7 # 40	7	6	5	4	3	2	1	0
F7	8 # 41	7	6	5	4	3	2	1	0
F8	9 # 42	7	6	5	4	3	2	1	0

CV # 61 = 1 or 2

Function	CV	FO12	FO11	FO10	FO9	FO8	FO7	FO6	FO5	FO4	FO3	FO2	FO1	rear	front
F0	#33							7	6	5	4	3	2	1	0
F0	#34							7	6	5	4	3	2	1	0
F1	#35							7	6	5	4	3	2	1	0
F2	#36							7	6	5	4	3	2	1	0
F3															
F4	#38														
E5															
E6															
F7															
F8	#42														
F9	#43														
F10	#44														
F11	#45														
F12	#46														
Richtungs-Bit															

Typical application: F3 (FO9): Sound on/off F5 (FO8): Bell F2 (FO7): Whistle when connecting a typically older sound module to an MX69V.

If CV # 61 = 1

If CV # 61 = 2

CV # 61 = 11 or 12

Function	CV	FO12	FO11	FO10	FO9	FO8	FO7	FO6	FO5	FO4	FO3	FO2	FO1	rear	front
F0	#33							7	6	5	4	3	2	1	0
F0	#34							7	6	5	4	3	2	1	0
F1	#35							7	6	5	4	3	2	1	0
F2	#36							7	6	5	4	3	2	1	0
E3															
F4	#38														
E5															
E6															
E7															
F8	#42														
F9	#43														
F10	#44														
F11	#45														
F12	#46														
Richtungs Bit															

Typische Anwendung: F3 (FO9): Sound ein/aus F7 (FO8): Glocke F6 (FO7): Pfiff bei Anschließung eines externen (meist älteren) Sound-Bausteines am MX69V

Wenn CV61 = 11 Wenn CV61 = 12

CV # 61 = 1, 2, 11, 12 is similar to the normal NMRA function mapping (which is CV #61 = 0), but,

... activation of the output **FO1** either (if CV # 61 = 1, 11) through the “direction bit” (respectively the driving direction) or (if CV # 61 = 2, 12) via F7.

... association of the functions F2, F3, F5 (if CV # 61 = 1, 2) or F6, F3, F7 (if CV # 51 = 11, 12) to the function outputs FO7, FO9, FO8, which is similar to an interface with older sound module (with inputs for bell, whistle, on/off)

CV # 61 = 3 or 4

Function	CV	FO12	FO11	FO10	FO9	FO8	FO7	FO6	FO5	FO4	FO3	FO2	FO1	rear	front
F0	#33							7	6	5	4	3	2	1	0
F0	#34							7	6	5	4	3	2	1	0
F1	#35							7	6	5	4	3	2	1	0
F2	#36							7	6	5	4	3	2	1	0
E3 vo															
E3 rü															
F4	#38														
E5															
E6															
E7															
F8	#42														
F9	#43														
F10	#44														
F11	#45														
F12	#46														
Richtungs-Bit															

Typical application: F3 (FO9): Sound on/off F5 (FO8): Bell F2 (FO7): Whistle when connecting a typically older sound module to an MX69V.

If CV # 61 = 1

If CV # 61 = 2

CV # 61 = 13 or 14

			FO12	FO11	FO10	FO9	FO8		FO6	FO5	FO4	FO3	FO2	FO1	hinten	vor-
F0	#33								7	6	5	4	3	2	1	0
F0	#34								7	6	5	4	3	2	1	0
F1	#35								7	6	5	4	3	2	1	0
F2	#36								7	6	5	4	3	2	1	0
F3 vor					●							●				
F3 rü					●			●								
F4	#38				7	6	5	4	3	2	●	1	0			
F5																
F6																
F7							●									
F8	#42		7	6	5	4	●	2	1	0						
F9	#43		7	6	5	4	●	3	2	1	0					
F10	#44		7	6	5	●	4	3	2	1	0					
F11	#45		7	6	●	5	4	3	2	1	0					
F12	#46		7	●	6	5	4	3	2	1	0					
Richtungs Bit																

Typical application: F3 (FO9): Sound on/off F5 (FO8): Bell F2 (FO7): Whistle
 when connecting a typically older sound module to an MX69V. If CV61 = 13 If CV61 = 14

CV # 61 = 3, 4, 13, 14 the most part identical to the allocations on the previous page (CV # 61 = 1, 2, 11, 12), however with a **direction dependant function F3**, which switches the outputs FO3 and FO6 in dependency of the driving direction (typical application are red rear lights).
 CV# 61 = 5 or CV # 61 = 15

NMRA Function	CV	Zifferntaste auf ZIMO Fahrpulten	Zusätzliche Funktionsausgänge an MX69V und MX690V zweite Stiftleiste					Funktionsausgänge an allen MX69 / MX690 erste Stiftleiste					Stirn hinten	Stirn vorne		
			FO12	FO11	FO10	FO9	FO8	FO7	FO6	FO5	FO4	FO3			FO2	FO1
F0	#33	1 (L) vr						7	6	5	4	3	2	1	0	●
F0	#34	1 (L) rü						7	6	5	4	3	2	1	0	●
F1	#35	2						7	6	5	4	3	2	1	0	
F2	#36	3						7	6	5	4	3	2	1	0	
F3		4 vor				●					●					
F3		4 rück				●		●								
F4		5 vor								●						
F4		5 rück												●		
F5		6														
F6		7														
F7		8														
F8	#42	U - 9	7	6	5	4	3	2	1	0						
F9	#43	U - 1	7	6	5	4	●	3	2	1	0					
F10	#44	U - 2	7	6	5	●	4	3	2	1	0					

F11	#45	U - 3	7	6	●	5	4	3	2	1	0					
F12	#46	U - 4	7	●	6	5	4	3	2	1	0					
Richtungs Bit																

CV # 61 = 15 CV # 61 = 5

CV #61 = 5 or 15: For electric and diesel locos where **headlights and taillights as well as cab lights** are to be actuated by one function key each (F3 and F4) independent of direction. Also included in this assignment are the functions F2 and F5 (if CV #61 = 5) or F6 and F7 (if CV #61 = 15) on outputs FA7 and FA8 (preferably for whistle / bell of older external sound boards). These allocations were retained from the MX69 predecessors MX65 and MX66.

CV # 61 = 6

NMRA Function	CV	Zifferntaste auf ZIMO Fahrpulten	Zusätzliche Funktionsausgänge an MX69V und MX690V zweite Stiftleiste					Funktionsausgänge an allen MX69 / MX690 erste Stiftleiste					Stirn hinten	Stirn vorne		
			FO12	FO11	FO10	FO9	FO8	FO7	FO6	FO5	FO4	FO3			FO2	FO1
F0	#33	1 (L) vr													●	
F0	#34	1 (L) rü														●
F0		vorw. wenn F3 aus													●	
F0		rück. Wenn F3 aus														●
F1	#35	2						7	6	5	4	3	2	1	0	
F2	#36	3						7	6	5	4	3	2	1	0	
F3		4 vor				●										
F3		4 rück				●										
F4		5 vor														
F4		5 rück														
F5		6														
F6		7														
F7		8														
F8	#42	U - 9	7	6	5	4	3	2	1	0						
F9	#43	U - 1	7	6	5	4	●	3	2	1	0					
F10	#44	U - 2	7	6	5	●	4	3	2	1	0					
F11	#45	U - 3	7	6	●	5	4	3	2	1	0					
F12	#46	U - 4	7	●	6	5	4	3	2	1	0					
Richtungs Bit																

CV # 61 = 6 for **Swiss Electro- and Diesel engines with shifting**; F3 controls, if either a single white light or the red lights will be used as rear lights.
 The FO1 and FO4 function outputs are individually controlled. (with direction key and F4);

Function mapping procedure with CV # 61 = 98:

This procedure allows free allocation of function outputs to function keys (on the cab) that is not possible by setting fixed values in configuration variables.

To carry out this procedure requires a bit more time and attention from the user.



Activation, preparation: Set the loco direction to “forward”, all functions off; the loco must be on the main track (not on the programming track); the whole procedure is performed with operations mode programming.

→ **CV # 61 = 98** Entering 98 to CV #61 (in operations mode) starts the actual allocation procedure..

The decoder is now in a special programming mode, which will not end until the whole programming procedure is completed or the loco is lifted from the track for a few second.

→ The decoder is now ready to accept the first function output allocation, starting with function output **F0 in the forward direction**.

The function outputs (as many as desired) to be assigned to F0 in forward direction, are now actuated with the corresponding function keys (i.e. FLf, FLr, F1...F12)

Because only one function key (**F0**) is available for FLf and FLr (headlights), it is necessary to press F0 repeatedly to select the desired configuration (which alternately actuates the front and rear headlights).

The assignment must be confirmed by pressing the **direction's key**.

→ The decoder is now ready to accept the next output assignment for **F0 but now for “reverse”**.

Continue as above! Again, once a selection is made press the **direction's key** to apply.

→ **Continue in the same fashion for all function keys** (28 function-direction-combinations)!

→ After the last function key (F12 “reverse”) has been assigned, the function outputs FLf and FLr (both headlights) are turned on to indicate the end of this programming procedure.

Confirm again by actuating the direction key

→ After confirmation, the finished allocations are **automatically activated** and CV #61 is set to “99”.

Deactivation : CV # 61 = 0 ... 97 (any value except 98 and 99) deactivates the function assignment and again activates the function mapping according to CV #33 to #46 or CV #61, if a value between 1 and 7 is entered. The assignment defined during this procedure though remains stored in the decoder.



Reactivating of already stored data

CV # 61 = 99 Reactivates the defined output allocations



The special effects (US-lighting, uncoupler, soft-start, etc.) can also be assigned using above procedure. CV's #125, 126, etc. always refer to actual outputs! It is possible to store and re-activate several function output allocations with the help of the “CV-set” feature!

For a better overview, the function keys are listed here in the sequence as they are defined:

1. F0 forward	2. F0 reverse	3. F1 forward	4. F1 reverse
5. F2 forward	6. F2 reverse	7. F3 forward	8. F3 reverse
9. F4 forward	10. F4 reverse	11. F5 forward	12. F5 reverse
13. F6 forward	14. F6 reverse	15. F7 forward	16. F7 reverse
17. F8 forward	18. F8 reverse	19. F9 forward	20. F9 reverse
21. F10 forward	22. F10 reverse	23. F11 forward	24. F11 reverse
25. F12 forward	26. F12 reverse		



An alternative method for directional functions:

According to the NMRA function mapping (see table on the right), only function F0 is influenced by directional changes, which switches headlights according to direction. All other functions F1 – F12 (and higher) are not influenced by direction.

The directional bits (0,1) in the “Special Effects” CV #125 to #132 (later: possibly more CV's in a special CV block) allow for more directional functions (i.e. F1, F2, F3...), if at the same time the actual “Effects” bits 2 – 7 remain at “0”



EXAMPLE 1: The red rear lights on the front and rear end of a locomotive are connected to FA1 and FA2; both are to be switched with F1 and should change with direction. In order to do that set CV #35 to “12” (Bit 2 for FA1 and Bit 3 for FA2), CV #127 to “1” and CV #128 to “2” - thus function output 1 is turned on in forward direction only and output 2 in reverse. Special effect codes in bit 2 - 7 all remain at 0



EXAMPLE 2: The taillights should not be switched individually and independent from the headlights as in the example above but rather **the two loco ends** should be properly lighted (white and red lights) and switched on/off with F0 (front) and F1 (rear). This allows turning all lights off on the appropriate loco end, if cars are coupled to the loco.

This can be achieved as follows:

Connect the front white headlights to function output “Front headlight” and front red taillights to function output 2; rear white headlights on function output 1 and rear red taillights on function output “Rear headlights”

CV #33 = 1 (= default, front white light on F0 “front headlights”), CV #34 = 8 (front red lights when F0 “rear headlights”), CV #35 = 6 (both rear white and red lights on F1!), CV #126 = 1 and CV #127 = 2 (Directional change of rear white and red lights with “Effect”-CV's).

Alternative method: Use the function mapping procedure CV #61 = 98; see earlier in this chapter!

4.17 The ZIMO „Input-Mapping“

Input-mapping lifts the limits of the NMRA function mapping (each function key only has 8 function outputs). Also the usable function keys (= external functions) can be quickly and easily adapted to the needs of the user and together for function outputs and sound functions without changing the internal function assignment, especially without alterations to the sound projects:

CV's # 400 ... 428

CV	Designation	Range	Default	Description
# 400	Input-Mapping for internal F0 meaning which function key switches the internal function F0 ?	0 1 - 28, 29 30 - 58 59 - 87	0	= 0: Key F0 (from the DCC-packet) is forwarded to an internally used F0 (1:1). = 1: Key F1 forwarded to an internal F0. = 28: Key F28 forwarded to an internal F0. = 29: Key F0 forwarded to an internal F0. = 30: Key F1 on F0, only in forward direction = 31: Key F2 on F0, only in forward direction = 59: Key F0 on F0, only in reverse direction etc.
# 401 - # 428	Input-Mapping for internal F1 ... F28	0 1 - 28, 29 30 - 58 59 - 87	0	Like input mapping above, but for instance: CV # 401 = 0: Key F0 on internal F1 = 2: Key F1 on internal F1 etc.

4.18 Dimming and low beam

Some output function should often not be operated with full track voltage. For example, 18 V-light bulbs should not be operated at full voltage when the track voltage can be up to 24 V (typical in large scale model trains). The brightness should be reduced.

The optimal solution in this case is to connect the plus poles of that equipment to a low voltage source of the decoder; (see chapter Installation and Connection). This way they are stabilized, and therefore they do not fluctuate with the track voltage (load, track resistance, etc.).

Alternatively or additionally (dimming works not only with full track voltage, but also the low voltage outputs) the voltage reduction per PWM-dimming (Pulse Width Modulation) is available with

CV # 60,

which defines the PWM key settings. Naturally this type of voltage reduction is interesting because CV #60 is easily changeable at any time.



Bulbs with voltage ratings as low as 12V can be dimmed with this PWM dimming function without damage even if track voltages are considerably higher; but not bulbs rated for 5V or 1.5V. Instead of connecting them to a normal positive pole on the decoder, they must be connected to a low voltage function; see Chapter Installation and Connection



LED's, on the other hand, require a series resistor; if however, the resistor is designed to operate at 5 V, the PWM dimming is also sufficient at a track voltage of 25V. (in this case the setting would be CV # 60 = 50, so a reduction by one fifth, 1/5th).

Generally CV # 60 works with all function outputs. Whenever the value is to be limited to certain outputs, dim mask CV's are used; see chart.

CV	Designation	Range	Default	Description
# 60	Dimming of the function outputs = Voltage reduction of the function outputs via PWM Generally valid for all function outputs.	0 - 255	0	Reduction of effective voltage on the function outputs per PWM (pulse width modulation); Useful to dim headlights for instance EXAMPLE VALUES: CV # 60 = 0: (equivalent to 255) full voltage CV # 60 = 170 2/3 of brightness CV # 60 = 204: 80% brightness
# 114	Dim mask 1 = Excludes certain function outputs from dimming per CV # 60 See dimming mask 2 for higher function outputs in CV # 152	Bits 0 - 7	0	List of output functions which are NOT operated with a reduced PWM voltage (for brightness) per CV # 60, but instead operate with the direct voltage from the utilized positive pole, meaning the max. track voltage or low voltage function Bit 0 - front headlight, Bit 1 - rear headlight, Bit 2 - function output FA1, Bit 3 - function output FA2, Bit 4 - function output FA3, Bit 5 - function output FA4, Bit 6 - function output FA5, Bit 7 - function output FA6. Bit value = 0: Output will be dimmed to the value defined in CV # 60. Bit value = 1: Output will not be dimmed switched on it is operated at maximum voltage. EXAMPLE: CV # 114 = 60: FA1, FA2, FA3, FA4 are not dimmed. Only the headlights are reduced.
# 152	Dim Mask 2 Excluding specific function outputs from dimming as per CV # 60 This is a continuation of Dim Mask 1 in CV # 114 and FA3, FA4 as direction bit mapping	Bits 0 - 5 und Bit 6	0 0 0	... continuation of CV # 114. Bit 0 - function output FA7, Bit 1 - function output FA8, Bit 2 - function output FA9, Bit 3 - function output FA10, Bit 4 - function output FA11, Bit 5 - function output FA12. Bit 6 = 0: normal = 1: direction bit mapping on FA3, FA4, meaning FA3 is switched on during reverse driving, FA4 is switched on during forward driving. (normal mapping for FA3, FA4 is invalid) Bit 7 = 0: normal = 1: direction bit mapping on FA9 meaning FA9 is switched on during forward driving.. (normal mapping for FA9 is invalid)

High Beam / Low Beam Headlights with the Low Beam Mask

One of the function keys, F6 (CV # 119) or F7 (CV # 120) can be defined as a low beam key. As required, the specific outputs can be dimmed during an on or off switched function (Bit 7, inverted value).

CV	Designation	Range	Default	Description
# 119	Low beam mask for F6 = Output assignment for (example) low/high beam headlights ATTENTION: During certain input settings of CV # 154 (Special output-configurations) the meaning of CV's # 119, 120, changes. Then it is no longer a low beam mask	Bits 0 - 7	0	Assigns outputs to be dimmed with F6 (CV # 60 determines dim value) Typical application: low-/high-beam. Bit 0 - front headlight, Bit 1 - rear headlight, Bit 2 - function output FA1, Bit 3 - function output FA2, Bit 4 - function output FA3, Bit 5 - function output FA4. Bit values = 0: no low beam function, Bit values= 1: Low beam with F6 key, brightness determined by value in CV # 60. Bit 7 = 0: normal value of F6. = 1: value of F6 is inverted. EXAMPLE: CV # 119 = 131: Headlights switch from low to high beam with function key F6.
# 120	Low beam mask for F7	Bits 0 - 7		Same as in CV #119 but for F7 key.

A „Second Dim Value“ with the help of the coupling-CV

In case the adjustable voltage reduction through CV # 60 is not sufficient and a different value is desired for other additional function outputs, and the uncoupling function for a vehicle is not needed, the coupling CV

CV # 115

can be used as an alternative dimming setting. The affected function outputs then must have in one of the

CV's # 125 ... # 132, # 159, # 160

the effect-code "uncoupling operation" assigned. See Chapter Effects for Function Outputs.

CV	Designation	Range	Default	Description
# 115	(Decoupler activation time) Or "Second dim value"	0 - 9	0	Active if "uncoupling" is selected (value 48) in CV #125.....132: Ten's digit = 0, if used as dim value One's digit = 0 to 9, hold power in percent of track voltage, 0 - 90%.

# 127 - # 132	special effects for outputs FA1, FA2, FA3, FA4, FA5, FA6		0	= 48 if used as dimming value # 127 → FA1 # 128 → FA2 # 129 → FA3 # 130 → FA4 # 131 → FA5 # 132 → FA6
CV	Designation	Range	Default	Description
# 159, # 160	special effects for outputs FA7, FA8		0	= 48 if used as dimming value # 159 → FA7 # 160 → FA8

4.19 Flashing-Effect

Flashing is actually a light effect just like all the others which are summarized in the CV's starting with #125; but for historical reasons, CV's #117 and #118 are used.

CV	Designation	Range	Default	Description
# 117	Flasher Outputs are assigned in CV # 118 Flashing-Mask	0 - 99	0	Duty cycle for flasher function: Tens place = on time (0 = 100msec.....9 = 1 sec) Ones place = off time Example: CV #117 = 55: Flashes evenly at the same ON/OFF time.
# 118	Flashing-Mask = Defines which outputs operate as flashers according to rhythm programmed in CV # 117.	Bits 0 - 7	0	Selects the outputs that are supposed to flash when turned ON. Bit 0 = front headlight Bit 1 = rear headlight Bit 2 = function output FO1 Bit 3 = function output FO2 Bit 4 = function output FO3 Bit 5 = function output FO4 Bit values = 0: no flasher Bit values = 1: output flashes when turned ON. Bit 6 = 1: FO2 flashes inverse! Bit 7 = 1: FO4 flashes inverse! EXAMPLES: CV #118 = 12: FO1 and FO2 are defined as flashers. CV #118 = 168: Alternate flashing of FA2 and FA4 (wig-wag).

4.20 Special Effects for Function-Outputs

(american and other light effects, smoke generator, coupling, et al.)

Collectively, effects can be assigned to 10 function outputs; this happens with

CV's # 125, # 126, # 127 ... # 132, # 159, # 160

for headlights front, headlights rear, FA1 FA6 , FA7 , FA8

The values that can be programmed into the effect CV's consist of

the 6-bit - effect - code and the 2-bit - direction - code

- Bits 1,0 = 00: directionally independent (always functions)
 = 01: functions only in forward direction (+ 1)
 = 10: functions only in reverse direction (+ 2)
- Bits 7 ... 2 = 000000xx no effect, only
 = 000001xx Mars light + direction = (0), 1, 2 (directionally independent, forw., rev.)
 = 000010xx Random Flicker + direction = 4, 5, 6 (directionally independent, forw., rev.)
 = 000011xx Flashing headlight + direction = 8, 9, 10
 = 000100xx Single puls strobe + direction = 12, 13, 14
 = 000101xx Double puls strobe + direction = 16, 17, 18
 = 000110xx Rotary beacon simul + direction = 20, 21, 22
 = 000111xx Gyalrite + direction = 24, 25, 26
 = 001000xx Ditch light type 1, right + direction = 28, 29, 30
 = 001001xx Ditch light type 1, left + direction = 32, 33, 34
 = 001010xx Ditch light type 2, right + direction = 36, 37, 38
 = 001011xx Ditch light type 2, left + direction = 40, 41, 42
 = 001100xx Uncoupling-operation: time-/voltage limitation in CV #115, = 48, 49, 50
 automatic departing during uncoupling in CV # 116
 = 001101xx "Soft start" = slow dim increase of the function output = 52, 53, 54
 = 001110xx Autom. Bremslicht für Straßenbahnen, Nachleuchten im Stillstand variabel,
 Nachleuchtzeit siehe CV # 63. = 56, 57, 58
 = 001111xx Automatic switch-off of the function output during speed step > 0
 (ex. turning off the driver's compartment light during driving). = 60, 61, 62
 = 010000xx Automatic switch-off of the function output after 5 min
 (ex. to keep a smoke generator from overheating). = 64, 65, 66
 = 010001xx as above, but automatic shut-off occurs after 10 min. = 68, 69, 70
 = 010010xx speed or last dependent **smoke generation**. = 72, 73, 75
 for **SMOKE-Locos** as per CV's #137 - 139 (preheating during
 standstill, strong smoke during fast driving or under heavy load.)
 Automatic switch off as per CV #353; after switch-off, turn back on
 with new function operations.
 = 010100xx Driving condition dependent **smoke generation** for **DIESEL-Locos** = 80, 81, 82
 as per CV#137-139 (preheating during standstill, strong smoke during
 start up of the motor and during acceleration). Suitable activation
 of the fan on the fan output. Automatic shut-off as per CV #353;
 Start up using new function operation.

The effect-CV's are suitable even **without effects** (effect-code 000000) for,
 direction dependent function outputs



EXAMPLE:

CV # 127 = 1, CV # 128 = 2, CV # 35 = 12 (FA1, FA2 directionally dependent, switch-able with function key F1).

CV	Designation	Range	Default	Description
# 125 ¹	special effects american lighting effects or uncoupler, automatic ON/OFF of function outputs according to various criteria "Soft Start" of function outputs Operates with F0 in forward direction by default, unless assigned different through function mapping. Effects can be modified with CVs # 62, 63, 64, und CV # 115, # 116 (for uncoupling).		0	Bits 1, 0 = 00: directionally indep. (always functions) = 01: active in forward direction only = 10: active in reverse direction only ATTENTION: in case of CV #125 and #126: change CV's #33, 34.... if direction is wrong Bits 7, 6, 5, 4, 3, 2 = effect code EXAMPLE: (Desired effect - you have to program into CV # 125) Mars light, only forward - 00000101 = "5" Gyalrite, independent of direction - 00011100 = "28" Ditch type 1 left, only forward - 00100101 = "37" Uncoupling-operation - 00110000 = "48" Soft-Start for output - 00110100 = "52" Autom. brakelights - 00111000 = „56“ Autom. turns off cab light at start - 00111100 = „60“ Speed or load dependent smoke generation - 01001000 = „72“ Speed or load dependent diesel smoke - 01010000 = „80“
# 126	Special effects for Rear headlight (default F0 reverse)		0	see CV # 125
# 127 - # 132	Special effects for outputs FA1, FA2, FA3, FA4, FA5, FA6		0	see CV # 125 # 127 → FA1 # 128 → FA2 # 129 → FA3 # 130 → FA4 # 131 → FA5 # 132 → FA6
# 159, # 160	Special effects for Outputs FA7, FA8		0	see CV # 125 # 159 → FA7 # 160 → FA8
# 62	Light effects modification	0 - 9	0	Change of minimum dimming value
# 63	Light effects modification or Stop light OFF delay	0 - 99 0 - 255	51	Tens place: sets cycle time (0 - 9, default 5) or start up time during soft start (0 - 0,9s) Ones place: extends "off" time If stop light is activated with value 56 in CV #125, 126 or 127: Time in tenths of a second (range: 0 – 25 sec.) the stop lights remain ON after the street car comes to a full stop.

¹ Special tip for ditch lights: Those are only active if the headlights (F0) are turned on as well as function F2: this is equivalent to the American prototype. The "ditch lights" only function, if the Bits in CV # 33 and # 34 are configured (the definition in CV # 125 - 128 is not sufficient, but additionally required). Example: If ditch lights are defined for FA1 and FA2, the Bits 2, 3 in CVs # 33, 34 must be on (e.g. CV # 33 = 00001101, CV # 34 = 00001110).

CV	Designation	Range	Default	Description
# 64Continued Light effects modifications	0 - 9	5	Ditch light off time modification
# 353	Automatic shut-down of smoke generator for STEAM and DIESEL engine	0 - 255 = 0 - 106 min	0	If the smoke generator is controlled by one of the Special Effects "010010xx" or "010100xx" in CV's 127 - 132 (for one of the function outputs FO1 to FO6), it will turn off automatically after the time defined here (to prevent overheating). = 0: Won't turn off automatically. = 1 ... 255: Switches off automatically after 25 seconds/unit. Maximum time therefore is about 6300 sec. = 105 minutes

4.21 Configuration of smoke generators

Non-pulsed smoke generators:
(Example: „Seuthe“ 18 V)

In addition to a simple ON/OFF function with any function output, the MX695 offers an easy solution for **changing smoke intensity** from a **stand still to full load**.

This requires the smoke generator to be connected to one of the function outputs FA1 to FA6 and the selected output must be programmed with the associated effect CV (CV #127 for FA1, CV #128 for FA2 etc.) for the desired effect: for load dependent smoke for steam engines (effect code "72") or load dependent smoke for diesels (effect code "80").



EXAMPLE: - Steam engine, smoke generator connected to function output FO5: CV #131 = 72. The selected function output is further defined by CV #137, 138 and 139 ("Definition of smoke generator characteristic"). These CV's must be programmed with appropriate values otherwise the smoke generator will not produce any smoke.



EXAMPLE: - Typical characteristic for a track voltage set around 20V with above smoke generator:

- CV # 137 = 70 .. 90: little smoke at standstill.
- CV # 138 = 200: the smoke generator is limited to about 80% of its maximum capacity beginning with speed step 1 (lowest speed step), which produces relative heavy smoke.
- CV # 139 = 255: During acceleration, the smoke generator is powered at maximum capacity, thick smoke.

CV	Designation	Range	Default	Description
# 137 # 138 # 139	Characteristics for smoke generators connected to FA's 1-6 (if the effect "smoke" is selected in the appropriate CV #127-132)	0 - 255 0 - 255 0 - 255	0 0 0	The values in CV #137 - 139 define a smoke characteristic for the function outputs (FA1, FA2, FA3, FA4, FA5 or FA6; referred to below as FAx), provided a "smoke function" for a diesel or steam engine has been selected in the associated CV #127 - 132 (i.e. 010010xx, 010011xx, 010100xx or 010101xx). CV #137: PWM of FOx at standstill

# 137	PWM at stand still			CV #138: PWM of FOx at cruising speed
# 138	PWM at cruising			CV #139: PWM of FOx at acceleration (PWM = Pulse With Modulation)
# 139	PWM during acceleration			

Synchronized steam chuff or typical diesel smoke with "ProLine Pulsed Smoke Unit"):

With the built-in fan, synchronized steam chuffs can be produced without any other additional electronic components.

The heating element of the smoke generator is connected - as in the example above with the "Seuthe" generator - on **FA1...FA8** and configured with the appropriate CV for the desired effect (i.e. "72" for steam or "80" for diesel).

The fan is connected to the ventilator output of the MX695; See Chapter "Installation and Wiring"

The following CV's must be programmed as follows:

CV #137, #138, #139 = 60, 90, 120 respectively: (IMPORTANT) the heating element of the USA Trains smoke generator is designed for maximum 9V, which requires that the voltage of that function output is limited. This is done with suitable values in CV #137, 138 and 139.

CV #133 = 1: (IMPORTANT) this configures output FA10 as a fan output.

CV # 353 = ...i.e. 10: shuts the smoke generator off automatically to prevent overheating. In this example (10) after 250 second

CV # 351, 352 = ...only for diesel engines when effect code "80" is selected in the applicable CV for FA1...FA6. This defines the fan speed (voltage) for start-up (maximum smoke) and cruising (default: medium smoke); see CV tab.

CV # 355 = ... for steam and diesel engines. Defines the fan speed (voltage) at standstill (usually for very little smoke output).

4.22 Configuration of electric decoupler

„ProLine Decoupler“, „System KROIS“, and „System ROCO“

If one (or two) of the function outputs **FA1 ... FA6** (not FA7, FA8), are not assigned the function effect "uncoupling" (CV # 127 für FA1, usw.), then the settings for the uncoupling operation and the entire uncoupling process are achieved using

CV # 115 und CV # 116

They limit the running time to prevent overheating, define a potential non-release voltage (ROCO system) as well as automatic push-on and push-off.

For the **Krois system**, CV # 115 = "60", "70" oder "80" is not recommended; this limits the uncoupling impulse (with max. voltage) to 2, 3 or 4 seconds; A definition of the remaining voltage is not necessary with the Krois system (therefore one's place "0").

CV	Designation	Range	Default	Description
# 115	Uncoupler control (Krois and ROCO) "Pull-in" time and	0 - 99	0	Active if "uncoupling" is selected (value 48) in CV #125.....132: Tens digit = 0 - 9, pull-in time in seconds of applied full voltage:

	“hold” voltage CV # 115 alternatively used for additional dim value (0-90% according to ones place; set tens place to 0)			Value: 0 1 2 3 4 5 6 7 8 9 Seconds: 0 0.1 0.2 0.4 0.8 1 2 3 4 5 One digit = 0 to 9, hold power in percent of track voltage, 0 - 90%. Applied after the pull-in time elap- sed (ROCO uncoupler)
# 116	Automated uncoupling procedure	0 - 99, 0 - 199	0	Ones digit (0 – 9) = x 4: Internal speed step applied to loco (Momentum per CV #3 etc.) Tens digit (0 – 9): Length of time the loco should move away from train; values as in CV #115. Hundredths digit: = 0: no tension relief. = 1: tension relief: loco moves toward coupler (to relieve tension) before uncoupling <u>Example:</u> CV #116 = 61: Loco uncouples and drives away from train for 2 seconds at speed step 4. CV #116 = 155: Loco pushes first against train to un- load couplers, uncouples and then drives away from train for 1 second at speed step 20.



Hints for automated uncoupling procedure; with coupler tension relief and loco/train separation

- The automatic train separation is activated as soon as the tens place in CV # 116 is other than 0; or as the case may be, if CV # 116 > 100 the loco automatically pushes against the adjoining coupler.
- The procedure (acceleration) takes place at the moment the coupler is activated, although only if the loco is at rest at the time of coupler activation (speed regulator in 0 position). If the loco is still moving, the procedure starts as soon as the loco comes to a full stop provided the button for this function is still being activated.
- The procedure ends when the function is turned off (by releasing the key if in momentary mode or by pressing the key again if in latched mode), or when the programmed time limits have been reached (CV #115 for the coupler and CV #116 for the loco detachment phase).
- Moving the speed slider during an automated uncoupling procedure stops the process immediately.
- The driving direction during coupler detachment is always according to the cab setting; directional settings in the “Effects” definition for uncoupling (Bits 0 and 1 of CV #127, CV #128 etc.) will not be applied.

5 ZIMO SOUND – Selecting and Programming

► Shipping decoders with a ZIMO “sound collection” installed is the preferred way of delivery and a specialty of the ZIMO sound concept, which is possible due to the large data storage capacity of the decoders: sound samples and CV parameters for several engine types are stored in each decoder. The preferred sound for a given locomotive can be selected with the cab (no need to load a different sound sample from the computer).

At the same time, the user is free to change acoustics of a locomotive to his/her own taste by selecting for example a chuff sound from 5 different chuff samples and a whistle from 10 available whistles (or several whistles on different function keys); furthermore a selection of bells, compressors, steam shovel, oil burner or break squeal etc.

The “sound collection” itself is a special form of the “sound Projects” (see below) and is also listed at www.zimo.at (under “UPDATE” and “decoder”), ready for download and installation in case the decoder wasn’t ordered with the desired sound files.

► **Shareware ZIMO sound apps (“Free D’load”)** are available from www.zimo.at (follow “UPDATE”, Decoder”), usually in two different versions:

1) as “**ready-to-use**” project: This is a .zpp file, which once downloaded, can be installed in to the decoder with the MXDECUP update module or MX31ZL cab (or MX10) and the help of the program **ZIRC (ZIMO Rail Center)** or with the MX31ZL and a USB stick (or MX10 and SD-card) directly, without the need of ZIRC. All function assignments, parameters and CV values that are part of the project will be installed as well.

Even though it is a ready-to-use project, many of the function assignments and settings can still be changed to suit your own taste after the project is installed, with the procedures and CV changes described in the operating manual.

2) as “**full-featured**” project: this is a .zip file, which cannot be directly installed into the decoder but must be unzipped and processed by the program **ZSP (ZIMO Sound Program)**. Function assignments and CV settings can easily be changed within ZSP and sound files can be edited with a sound editing program or replaced with files from other collections.

After the sound project has been edited, it can be loaded in to the decoder from the program ZSP via the MXDECUP or MX31ZL (or MX10). Individual adjustments can be made to the decoder with the procedures and CV’s explained in this manual. The new decoder values can be backed up by sending the data back to ZSP.

► **PROVIDER sound apps (“Coded Provider”)** are also available for a **small fee** from the **ZIMO sound database**, but can only be used with “**coded decoders**”, which are decoders containing the load code. “Coded decoders” are bought as such (for a small surcharge) or converted by buying and installing the **load code** in to normal decoders at a later date. The load code is only valid for one decoder (identified by the **decoder ID**), but entitles the buyer to use all sound projects of a specific sound bundle (i.e. all sound projects from Heinz Däppen). Also see the ZIMO sound database in the UPDATE pages at www.zimo.at.

“Coded Provider” projects are contributions by external ZIMO partners (shown as “Provider” in the ZIMO data base such as Heinz Däppen for Rhätische Bahnen and US steam engines), who are paid for their efforts through the sale of the “Load codes”.

► “Preloaded” PROVIDER sound projects are installed at the factory. The applicable “load code” fee applies and is added to the decoder price.

The “preloaded” sound projects are not just available as a temporary substitute for a download with a load code, but also for many other custom sound projects (for free and for a small fee).

► During operation the sound impressions are adjustable through incremental programming. Instead of experimenting with different CV values, the values can be adjusted and fine tuned by gradually increasing and decreasing the values ...

- how the sound should react to inclines, declines and acceleration events. This allows for a fast adaptation to changing operating situations (single engine or engine on heavy goods train);

- when the water drainage sound should be played at start up, or the break squeal when stopping the train; and many others

Loco type selection with CV #265 – current layout for MX690 with SW version 18:
 (Software and organization of sound will undergo changes over time; CV #265 is not yet final)

CV	Description	Range	Default	Description
# 265	Selection of engine type	1	1 or 101	= 0, 100, 200: Reserved for future applications
		2	Steam engine	= 1, 2, ... 32: Selection from pre-loaded steam sounds for example for engine BR01, BR28, BR50, etc.. Steam chuffs as well as other sounds (whistle, compressor, bells, ...) can be adjusted.
		...	1	= 101, 102, ... 132: Selection from Diesel sounds (if different sounds are in collection).
		101	or Diesel	
		102	101	

Attention: For now, only one diesel sound can be installed (CV #265 = 101).

Operating the sound decoder for the first time (European steam edition):

As delivered, the MX690 comes with typical engine sound activated and function-sounds allocated to function keys

Funktion F8 – turns engine sounds on/off

sounds activated by function keys remain active regardless (an on/off key can be assigned for these as well with CV #311, which could also be F8).

The sound in case of the MX690 with “European steam sound” is of a 2-cylinder engine (the chuff rate can only be approximate without further tuning) with automated water drainage and brake squeal as well as some randomly played stationary sound.

The following functional sounds are allocated to these **function keys**:

- F2 – short whistle
- F4 – water drain (blow-off ...)
- F5 – long whistle (playable)
- F6 – bell
- F9 – compressor
- F10 – generator (also comes on with F0)
- F11 – Injector
- F7 – coal shoveling or oil burner

F0, F1 and F3 are not allocated for sound by default since they are usually required for other tasks.

The following stationary sounds are allocated to the **random sound generator**:

- Z1 – compressor
- Z2 – coal shoveling
- Z3 – injector

The switch inputs are allocated to the following by default:

- S1 – long whistle
- S1 – nothing
- S3 – cam sensor

Special procedures for owners of non-ZIMO DCC systems:

(Owners of ZIMO MX1 “model 2000” -EC or - HS command stations can skip this half page)

Configuration variables #266 to #355 are used for the selection and allocation of sound samples as well as other settings. Programming CV’s in this range is no problem for high-level systems (such as the current ZIMO DCC systems) both in “service mode” or “operations mode”.

There are however many DCC systems in use (some still in production) that can only access CV’s up to #255, to #127 or even worse to #99.

If the range of values for CV’s is limited (ex. Only 0 to 99 instead 0 to 255) see CV # 7 !

For such applications, ZIMO sound decoders offer the alternative way of reaching higher CV numbers via lower numbers. This is done with an initial “Pseudo-Programming” of

CV # 7 = 110, = 120 or = 130,

which increases the CV numbers about to be accessed by 100, 200 or 300. For example:
 If programming CV #266 = 45 is not possible, programming CV #7 = 110 followed by CV #66 = 45 executes the desired programming of CV #266 = 45

or

if neither CV #266 = 45 nor CV #166 = 45 is possible, programming CV #7 = 120 followed by CV #66 = 45 also leads to the result of CV #266 = 45.

The initial CV #7 – “Pseudo-Programming” state – remains active for further programming (which means CV #267 is entered as #167, CV #300 as #200 and so on) until the decoder is powered down. ATTENTION: After re-booting the system, the “Pseudo-Programming” is lost, that is programming CV #166 is indeed accessing CV #166 again. See below to prevent this!

With **CV # 7 = 0**,

the “Pseudo-Programming” is stopped, which means that programming CV #166 is again programming this CV.

The initial “Pseudo-Programming”

CV # 7 = 210 or = 220,

achieves the same results as above but remains active even after the system is powered down. This state can only be cancelled with

CV # 7 = 0,

which is important to remember if once again lower CV’s need to be programmed!

Also see CV #7 for systems that are not capable of programming high values (>99)!

Selecting a new or replacing the current chuff set:

The following procedures are always used in the same way in spite of the flexible decoder layout with different sound sample compilations. It is also worth mentioning that the sound samples can be listened to and evaluated under actual operating conditions (with the engine running), not just on the computer.

The **selection procedure** is started with a "Pseudo-Programming" in operations mode ("on-the-main"):

CV # 300 = 100 (only for steam / not possible with DIESEL engines!).

The "Pseudo-Programming" (meaning that the entered value is not really stored in memory) has the effect that the function keys F0 to F8 no longer actuate function outputs but instead are now available for special tasks within the sound selection procedure. The function keys should be set to momentary, if possible, which would facilitate the procedure.

The function key identifications (and the MX31 cab displays) shown are typical for a ZIMO cab during the selection procedures (and for other sound adjustment procedures) but **is analogous to the function keys of third party cabs** although in a different

The function keys have the following special meaning during the selection procedure!

Key assignment for ZIMO MX31/MX32:

- ☞ 1 F0 ☞ 2 F1 ☞ 3 F2
- ☞ 4 F3 ☞ 5 F4 ☞ 6 F5
- ☞ 7 F6 ☞ 8 F7 ☞ 9 F8



- F0 = play :** plays back the current chuff sound for evaluation; only possible with the engine at standstill; the chuff sounds are played automatically when the engine is moving.
- F1, F2 = prev, next :** plays back the previous or next recording stored in the decoder; the sound file can immediately be evaluated with the engine stopped, with the engine running the selected file replaces the currently active.
- F3 = CLEAR + end :** The **selection procedure** is stopped and the selection is cleared, that is no chuff sound will be played (boiling and blow-off sound remains).
- F8 = STORE + end :** The **selection procedure** is stopped with the last selected chuff set replacing the current set.

The **selection procedure** is also stopped when programming anything else (e.g. CV #300 = 0 or any other value but also any other CV) or by turning off power to the system. In these cases, the current chuff set remains. Such "forced endings" are also useful when the "old" sound should remain as the current sound without first having to locate it again.

The selection procedure is supported with **sound signals**:

The "cuckoo jingle" (confirmation jingle) sounds when:

- the last stored chuff sound is reached; use the key to scroll in the opposite direction (F1, F2) to listen to the other stored chuff sounds,
- play-back is tried (F0) but no sound sample available,
- a wrong key is pressed (F4, F5 etc.)

The "**confirmation jingle**" is played after ending the selection procedure with F3 or F8.

The engines can be **operated normally** during the selection procedure: with speed regulator, direction key and MAN key (the latter only with ZIMO cabs); functions cannot be actuated until the selection procedure is terminated with F3, F8 or by other programming steps, see above.

Selecting boiling, whistle, blow-off and brake squeal sounds

The selection procedures for these "automated background sounds" are initiated with a "Pseudo Programming" in operations mode programming

CV # 300 = 128 for the boiling sound (STEAM only)

CV # 300 = 129 for direction-change sound

CV # 300 = 130 for the brake squeal

CV # 300 = 131 thyristor-control sound (electric engine)

CV # 300 = 132 for the "start" whistle

CV # 300 = 133 for blow-off sound =cylinder valves (STEAM only)



NOTE: the blow-off sound selected here is also used as the blow-off sound actuated with a function key (see CV #312).

CV # 300 = 134 for the driving sound of ELECTRIC engines

CV # 300 = 136 for the switchgear sound of ELECTRIC engines

The selection procedure for background sounds is the same as for the selection of chuff sounds EXCEPT: the engine should be at a **stand still** because the **speed regulator** is used for **setting the volume** for the relevant sound file!



Note: these sound files can also be used as function sounds allocated to function keys (see next page); the automated background sounds can then be cancelled with function keys .

The function keys have the following special meaning during the selection procedure, speed regulator is used for volume setting!

- ! ☞ 1 F0 ☞ 2 F1 ☞ 3 F2
- ☞ 4 F3 ☞ 5 F4 ☞ 6 F5
- ☞ 7 F6 ☞ 8 F7 ☞ 9 F8

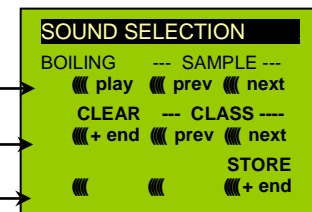

Function keys are used to the chuff selection process:

- F0 = play:** plays back the currently selected sound
- F1, F2 = prev., next:** plays back the previous or next recording.
- F4, F5 = prev., next:** switches between sound groups.

The **speed regulator** acts as volume control for the background sound during selection procedure.

F3 = CLEAR + end: Selection procedure is stopped and the current sample removed.

F8 = STORE + end : Selection procedure is stopped and new selection activated.

The selection procedure can also be ended by any other programming procedure or by removing power.

Normal function outputs cannot be activated as long as the selection procedure is active.

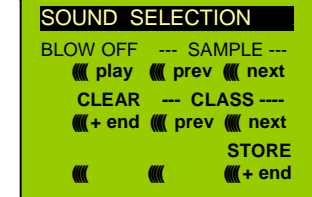
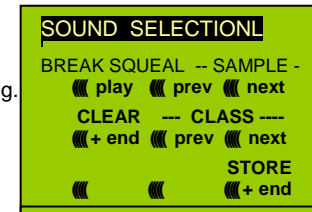

A simplified procedure (w/o CV #300) is available with MX31 (SW1.22 or higher) or MX31ZL (SW3.06 or higher).

Allocating sound samples to function keys F1 ... F12:

A sound sample can be allocated to each function key F1...F12 from the sound samples stored in the decoder. It is absolutely permissible to have a function key assigned for a function output (FA1, FA2 etc.) as well as for a sound function, both of which will be activated when the key is pressed.

The **allocation procedure** for function sounds are initiated with a "Pseudo-Programming" in operations mode programming:

- CV # 300 = 1 for function F1
- CV # 300 = 2 for function F2
- etc. until F19
- CV # 300 = 20 for function F0 (!)

Note: Function F4 is by default used for water drainage sound (with CV #312); if F4 is to be used for something different, CV #312 must be set to zero (CV #312 = 0).

The allocation procedure is very similar to the selection procedures for driving and background sounds, with the difference that sound allocation is not limited to sound samples of a certain group but also allows switching between groups to find the desired sample.

Sound samples are organized in **groups** for easier usage; i.e. "short whistle" / "longes whistle" / "horn" / "bell" / "shoveling coal" / "announcements" and much more

The engine should remain at **standstill** since the **speed slider** is used as **volume control** during this allocation procedure!

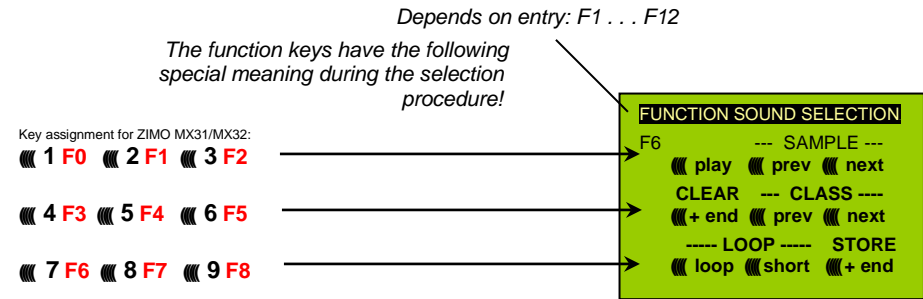

- F0 = play** : plays back the current chuff sound for evaluation.
 - F1, F2 = prev, next** : plays back the previous or next recording stored in the decoder.
 - F4, F5 = prev, next** : switches between sound groups (e.g. whistles, bells etc.); plays back the first sample of this group.
- The **speed regulator** acts as volume control for the selected sound during allocation procedure.
- F6 = loop** : If F6 is "on" when exiting the allocation procedures, the sound sample is stored and played back as long as the relevant function key is pressed by repeating the sound between the loop marks (the loop marks are part of the sound file).
 - F7 = short** : If F7 is "on" when exiting the allocation procedures, the sound sample is shortened and played back for the duration of the function actuation, by omitting the center portion.

Note: F6 and F7 are only effective provided the markers are included in the sample; basic settings are also saved; changes take effect only if F6 or F7 is actuated.

If F6 or F7 are not actuated, the sound sample then is always played back in the length it was saved regardless how long the function key is pressed.

- F3 = CLEAR + end** : The **allocation procedure** is **stopped** without a sound allocated to this function key.
- F8 = STORE + end** : The **allocation procedure** is **stopped** and the last selected function sound is stored and played back when this function key is pressed.

The **allocation procedure** can also be **ended** by any other programming procedure (e.g. CV #300 = 0 or any other value or CV) or by removing power from the decoder. The "old" allocations remain active in such cases; such "forced endings" are also useful when the "old" sound should remain as the current sound without first having to locate it again.

The selection procedure is supported with **sound signals**:

The "cuckoo jingle" sounds when:

- the last stored sound sample of that group is reached; use the key to scroll in the opposite direction (F1, F2) to listen to the other stored sounds,
- the last stored sound group is reached (with F4 or F5); use the other key (F4 or F5) to scroll in the opposite direction.
- play-back is tried (F0) but no sound sample available,
- a wrong key is pressed.

The "confirmations jingle" is played after ending the allocation procedure with F3 or F8.

A simplified procedure (w/o CV #300) is available with MX31 (SW1.22 or higher) or MX31ZL (SW3.06 or higher).

Allocation of sound samples to the random generators Z1...Z8:

The MX690 decoders provide 8 simultaneously playing random generators who's timing is determined by CV's; see "CV table" from CV #315.

Each random generator can have a sound sample that has been saved in the decoder assigned to it.

The **allocation procedure** for random sound is initiated with "pseudo-programming" in the operations mode ("On-the-main")

- CV # 300 = 101 for random generator Z1 (Z1 has special logic incorporated for the compressor and should therefore always be used for that)
- CV # 300 = 102 for random generator Z2
- CV # 300 = 103 for random generator Z3
- etc.

depends on entry: Z1 . . . Z8

The **allocation procedure** for random sounds is started with the "Operational mode" ("On-the-main") Pseudo-Programmierung

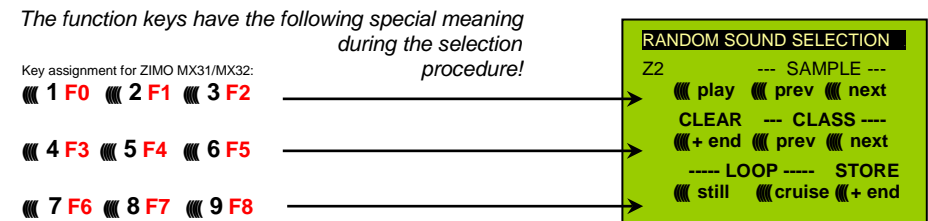

The meaning and actions of the function keys just like for the function sounds (see above),

- F0 = play** : play back
- F1, F2 = prev, next** : play back of previous or next sound sample and so on but
- F6 = still** : If F6 is active when ending the allocation procedure, the sound sample is played as random sound at standstill only (default).
- F7 = cruise** : If F7 is active when ending the allocation procedure, the sound sample is played as random sound when the locomotive is moving.

 **The allocation procedure for random sound is the same as for function sound!**

Simplified procedure (without using CV #300) with MX31, SW1.2 or MX31ZL, SW3.06

Allocation of sound samples to switch inputs S1, S2, S3:

The MX690 has 3 switch inputs available on connector #2. Input 1 and 2 are free for any function input while the third input is most often used for the cam sensor. If no cam sensor is available, that output can of course also be used for another function. These inputs can accept reed switches, optical or hall-effect sensors and similar; see chapter 8.

A sound sample can be allocated to each switch input, from the pool of stored samples in the decoder; play-back times can be set with the help of CV's #341, 342 and 343, see CV table.

The switch input **allocation procedure** is initiated with the operations mode Pseudo-Programming

- CV # 300 = 111 for switch input S1
- CV # 300 = 112 for switch input S2
- CV # 300 = 113 for switch input S3
- and so on...
- depends on entry: Z1 . . . Z8

The function keys have the following special meaning during the selection procedure!

Key assignment for ZIMO MX31-/MX32

-  **1 F0**  **2 F1**  **3 F2**
-  **4 F3**  **5 F4**  **6 F5**
-  **7 F6**  **8 F7**  **9 F8**



The meaning and action of the function keys is the same as for function sounds (see above):

- F0 = play** : play back
- F1, F2 = prev, next** : play back of previous or next sound sample and so on.

Automated recording of the motors "basic load" factor:

The following procedure is necessary to enable load dependent chuff sounds (volume and sound changes with inclines and load....) that is, to optimize the current values.

Technical background:

The load dependent sound is based on EMF (Electro Motive Force) measurements inside the decoder, which is primarily used for keeping the motor speed constant with changes in load, also known as BEMF. For the decoder to produce the correct sound for the respective driving conditions it has to know first what these measurements are at normal no-load cruising speed (smooth rolling of the engine or train on straight level track) that is, the "basic load" of an engine or train, which due to gearbox losses, power pick-ups etc. is often considerably higher on model trains than on the real railroad. Deviations from this "basic load" will then be interpreted as inclines or declines, which will result in analogously changed chuff sounds.

Initiated with "Pseudo-Programming"

CV # 302 = 75

an automated run is performed to record the "basic load" factor in forward direction;



ATTENTION: the engine (or the train) is driven automatically in forward direction for which unoccupied track must be available of at least 5 meters (15 feet), with absolutely no inclines or declines and without any (tight) curves.

With

CV # 302 = 76

an automated recording run can be performed in reverse direction, for locomotives that have different "basic loads" in the reverse direction (otherwise, reverse is considered identical to forward).



Note: A "heavy" train (a train with higher rolling resistance due to power pick ups of lighted coaches for example) may have a different "basic load" than an engine with nothing on the hook. A separate recording run may be required for such situation in order to obtain the best load dependent sound.

For easier handling of different "basic loads", provisions will be made with a future SW version that allows the recording of several "basic load" factors and the easy switching between a light running locomotive and a "heavy" train.

Sound CV's and their programming:

Configuration variables are for optimizing the sound effect for a specific locomotive and for special operating situations. The **programming** can be done either on the programming track in **service mode**, on the main track in **operations mode** or with "incremental programming".

The "incremental programming" is a special process or the "operations mode" programming with the following fundamental principle: the CV's are not programmed with an absolute value (as is normally the case) but rather the current value of a CV is being incremented or decremented by a fixed value (defined in the decoder for each CV).

The function keys of the cab temporarily serve as instruments for the incremental programming during which they cannot be used to actuate function outputs. The function keys are assigned to this with the "Pseudo-Programming"

CV # 301 = 66,

which changes the function keys to INC and DEC keys, first for CV #266 (that is the CV number derived from the value 66 + 200).

Several CV's are grouped together in one procedure for an easier and better handling. In the case of CV #301 = 66 is not only the leading CV #266 assigned for incremental programming but CV #266, #267 and #268 as well.

This is again shown here by means of the ZIMO cab (with the planned special MX31 display) but is valid analogous for the function keys of other cabs.

The function keys have the following special meaning during the selection procedure!

Key assignment ZIMO MX31/MX32:

- 1 F0 2 F1 3 F2
- 4 F3 5 F4 6 F5
- 7 F6 8 F7 9 F8

Incrementieren!

Decrementieren!

Aus Default-Wert setzen!

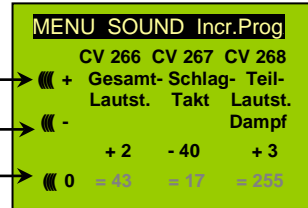

The last line shown in gray (absolute CV values) will no be available until bidirectional communication is being implemented!

- F0, F3, F6** Incrementing, decrementing and default setting of the lead CV number that was entered during the "Pseudo-Programming" initiation CV #301 = ... (or via menu with the MX31).
- F1, F4, F7** Incrementing, decrementing and default setting of the second CV number of that group; which CV's that are part of a group is shown in the CV table or is indicated in the ZIMO MX31 cab display.
- F2, F5, F8** Incrementing, decrementing and default setting of the third CV number of that group (if the group includes 3 CV's).

The incrementing and decrementing of CV values (usually in the 0...255 range) takes place in steps of 1, 5 or 10; this is predefined by the decoder software and cannot be changed. Intermediate values can be entered by direct CV programming, which in reality is hardly necessary.

The "cuckoo jingle" sounds when:

- the upper or lower end of a CV value range is reached!

The value of a particular CV can only be determined by reading it out on the programming track as long as the bidirectional communication is not available (which is of course implemented hardware wise on the MX690 and requires only a software update to be fully implemented). Although, most of the time this is not necessary since the reaction to a changed CV value can immediately be heard by the changing sound.



Note: All CV and parameter sets can be read out and written to the decoder and, if required, edited with a computer with the help of the MXDECUP programming module!

CV tables for SOUND CONFIGURATIONS:

The following CV's can be programmed both "normal" (i.e. CV #... = ...) and "incremental" (Exception: CV #280 for diesel engines). "Incremental programming" is especially useful when the proper value cannot be calculated in advance and must be determined by trial, which is often the case with many sound parameters.

The "Lead CV" in each case is the first of 3 consequential CV's that are edited and shown on the same screen of a ZIMO MX31 during the "incremental programming" procedure

CV	Designation	Value Range	INC Steps	De-fault	Description
# 265	Loco type selection	See introduction in Chapter ZIMO Sound !			
LEAD - CV # 266	Total volume	0 - 255	5	65	The value "65" results (mathematically) in the highest possible distortion-free play back volume; but values of up to 100 can be perfectly suitable because distortions in this volume range are hardly audible. Plus, the usefulness of a sound also depends on the quality of the sound sample.
# 267	Chuff sound frequency with „virtual cam sensor“für DAMPF-Lok For STEAM engines see also CV # 354	0 - 255	1	70	CV #267 active only if CV # 268 = 0: Chuff beats follow the "virtual cam sensor"; an actual cam sensor is not needed in this case. The default setting "70" results in about 4, 6 or 8 chuff's per wheel revolution, depending on the chuff set selected; because it also depends in large part on the motor and gearbox used, an individual adjustment is necessary in most cases in order to achieve the desired chuff frequency. This is the reason for CV #267: The lower the value the higher the chuff frequency and vice versa. The setting should be performed at lower speeds (around speed step 10), but not at the lowest speed step 1.
# 268	Switching to real cam sensor and trigger count for chuff rate For STEAM engines	0 - 255	1	0	= 0: "Virtual" cam sensor is active (to be adjusted with CV #267, see above). = 1: real cam sensor is active (connected to switch input 3 of the X690, see chapter 8); each positive rise results in a chuff beat. = 2, 3, 4, ... real cam sensor, several triggers in sequence (2, 3, 4 ...) result in a chuff beat.
LEAD - CV # 269	Lead-chuff accentuated. For STEAM engines	0 - 255	10	0	A typical sound signature of a passing steam engine is that out of a group of 4 or 6 steam chuffs, one of them always is more accentuated; this effect is in itself already part of the chuff sample set but can be amplified with CV #270.
# 270	PROJEKT not functional yet: Longer chuff length at very low speeds	0 - 255	10	?	PROJECT (not functional yet): The chuff sounds of a real engine are extended when driving at very low speeds due to the mechanical valve control. This effect can be more or less accentuated with CV #270.
# 271	Overlapping effect at high speed For STEAM engines	0 - 255 (useful up to about 30)	1	16	The individual steam chuffs should overlap each other at high speed like on a real engine. Because the frequency of the chuffs increase but won't shorten to the same extend they will eventually blend in to a weakly modulated swoosh. This is not always desired in model railroading because it doesn't sound that attractive, hence

CV	Designation	Value Range	INC Steps	De-fault	Description
					CV #272 with which an adjustment is possible whether the chuffs should be accentuated at high speed or rather fade away.
LEIT - CV # 272	Blow-off duration <u>For STEAM engines</u>	0 - 255 = 0 - 25 sec	10	50 = 5 sec	Opening the cylinder valves on a prototype steam engine for the purpose of water drainage is entirely up to the engineer. An automated draining at start-up is more suitable in model railroading; CV #272 defines how long after start-up the blow-off sound should play. Wert in CV # 272 = Zeit in Zehntel-sec! Note: If the blow-off sound is also allocated to a function key (on F4 as delivered, see CV #312), the automated blow-off sound can be shortened or extended with the relevant function key. Automated blow-off and function blow-off are inevitably the same (per selection/allocation). = 0: no blow-off sound played back
# 273	Delayed start after blow-off <u>For STEAM engines</u>	0 - 255 = 0 - 25 sec	1	0	Opening the cylinder valves and with it the related blow-off sound on a real steam engine starts most often before the engine even starts to move. This can be imitated with CV #273 by automatically delaying the start. This effect is cancelled when a shunting function with momentum deactivation is being activated (see allocation of F3 or F4 in CV #124!) = 0: no delay = 1: Special setting for blow-off via speed regulator; no delay but the lowest speed step means "no driving but blow-off instead" (only with 128 speed steps). = 2: Start-up delay in tenths of a second, Recommendation: no value > 20 (> 2 sec)
# 274	Blow-off schedule <u>For STEAM engines</u>	0 - 255 = 0 - 25 sec	10	30	During shunting operations that often requires many short trips with associated idle times, opening and closing the cylinder valves every time is not usually done. CV #274 causes the blow-off sound to be suppressed if the engine wasn't standing still for the time defined here. Value in CV #274 = time in seconds x 10! Shunting with permanently open cylinder valves can be achieved by actuating the function key that is assigned for blow-off sound (F4 by default or by function key assignment with CV #312 = 2, 3, 4..., see above).

CV	Designation	Value Range	INC Steps	De-fault	Description
LEIT - CV # 275	Engine (chuff) sound volume at low speed and no-load for STEAM engines: Smoke Chuffs for DIESEL engines: engine sound for ELECTRIC engines: often responsible for vent sounds (responsible for thyristor and engine CV's starting at # 289)	0 - 255	10	60	To set up load dependent sound do the following in the order shown: "Automated recording of the motor's "basic load" factor"; see above! Adjusting sound volume in CV #275 and #276. Adjusting CV #277 (should have been "0" up to this point), see below! If required also CV #278 and #279. With this CV the chuff volume at "basic load" (that is under the same conditions as during the automated recording run) is adjusted at about 1/10 of full speed. Note: For practical purposes (but not absolutely necessary), CV #275 is set to the proper value by trial using the "incremental programming" at low speed. Because the volume at various speeds is interpolated between the values in CV #275 and #277 it is not necessary to run at an exact speed step during this set-up, as long as it is around 1/10 of full speed This adjustment is best performed with CV #277 set to "0" (default) so that the setting for "unloaded driving" is not influenced by load factors.
# 276	Engine (chuff) sound volume at high speed and no-load	0 - 255	10	80	Same procedure as in CV #275 above, but for high speed. CV #276 defines the "no-load" chuff sound volume at full speed. Set the speed regulator to maximum during this set-up. All notes in CV #275 are also valid for this CV!
# 277	Degree of volume change under load for driving (chuff) sound.	0 - 255	10	0 = keine Reaktion	When deviating from the basic load (as determined by the "Automated recording of the motor's "basic load" factor", see above) the chuff beat volume should be increasing (on inclines) or decreasing (or muted) on declines. CV #277 defines the degree of change, which is to be set to the proper value by trial.
LEAD - CV # 278	Load change threshold	0 - 255	10	0	With this CV, a change in sound to small load changes can be suppressed (i.e. in curves) in order to prevent chaotic sound impressions. Suitable settings can only be determined by trial (with "incremental programming).
# 279	Reaction time to load change	0 - 255	1	0	This CV determines how quick the sound reacts to load changes, whereas the factor is not just time but rather "load-change dependent time" (the bigger the change the faster the effect). This CV is also used to suppress chaotic sound changes. Suitable settings can only be determined by trial

CV	Designation	Value Range	INC Steps	De-fault	Description
					(with "incremental programming" of CV's #278 and #279 together).
# 280	Load influence for DIESEL engines	0 - 255	10	0	This CV determines (at least temporarily in SW version 15) the reaction of the diesel sound to load: RPM levels and load steps of dieselhydraulic engines cruise/idle rpm of dieselectrics and shift points of geared engines. = 0: no influence, dependent on motor rpm up to 255: large influence. It is highly recommended that the automated test run with CV #302 = 75 is performed first (see text above under CV #302).
LEIT - CV # 281	Acceleration threshold for full load sound	0 - 255 (internal speed steps)	1	1	Compared to the "basic load", more powerful and louder chuff sounds should be played back for increased power requirements during accelerations. As is the case with the prototype, the increased sound should be noticeable before the increase in speed becomes visible, since the latter is a result of the increased steam volume supplied to the pistons. It is therefore practical that the heavy acceleration sound is played back when the speed has increased by just one speed step (when no real speed change is noticed), to be able to control the proper sound sequence with the speed regulator. The "engineer" can in this fashion adjust the sound (by increasing the speed by 1 step) in anticipation of an imminent incline. = 1: Acceleration sound played back at full volume if speed has increased by just one speed step. = 2, 3, ... Acceleration sound played back at full volume only after increasing speed by this number of speed steps; before that: proportional volume.
# 282	Duration of acceleration sound	0 - 255 = 0 - 25 sec	10	30 = 3 sec	The acceleration sound should remain for a certain length of time after the speed increased (otherwise each single speed step would be audible, which is unrealistic). Value in CV #282 = time in seconds x 10!
# 283	Engine sound volume at full acceleration	0 - 255	10	255	The volume of steam chuffs at maximum acceleration is set with CV #283 (default: 255 = full volume). If CV #281 = 1 (acceleration threshold set to 1 speed step), the volume defined here is applied with every speed increase (even if increased by just 1 step).
LEAD - CV # 284	Threshold for deceleration sound	0 - 255 (internal speed)	1	1	Steam chuffs should be played back at less volume (or no sound at all) signifying the reduced power requirement during deceleration. The sound reduction logic is analog to a reversed ac-

CV	Designation	Value Range	INC Steps	De-fault	Description
		steps)			celeration (per CV #281 to #283). = 1: Reduces sound to minimum (as per CV #286) when speed is reduced by just 1 step. = 2, 3, ... sound reduced to minimum after lowering speed by this number of steps.
# 285	Duration of reduced volume on deceleration	0 - 255 = 0 - 25 sec	10	30 = 3 sec	After the speed has been reduced, the sound should remain quieter for a specific time (analog to the acceleration case). Value in CV #285 = time in seconds x 10
# 286	Volume level during deceleration	0 - 255	10	20	CV #286 is used to define the chuff volume during deceleration (Default: 20 = pretty quiet but not muted). If CV #284 = 1 (deceleration threshold set to 1 speed step), the volume defined here is applied with every reduction in speed (even if decreased by just 1 step).
LEAD - CV # 287	Brake squeal threshold	0 - 255 (internal speed steps)	10	20	The brake squeal should start when the speed drops below a specific speed step. It will be automatically stopped at speed 0 (based on back-EMF results).
# 288	Minimum driving time before brake squeal	0 - 255 = 0 - 25 sec	10	50	The brake squeal is to be suppressed when an engine is driven for a short time only. That is usually a shunting run and often without any cars (in reality it is mostly the cars that are squealing not the engine itself!). Note: Brake squeal sounds can also be assigned to a function key (see allocation procedure CV #300 = ...), with which they can be played manually or stopped!
# 289	Thyristor control: Sound pitch for stepping effect of ELECTRIC engines From SW version 20	1 - 255	10	1	The pitch of the thyristor control sound of many engines (typical example: Taurus) should not ascend evenly but rather in steps. = 1: no stepping effect, even ascend 1 - 255: ascending scale according to the corresponding speed step interval.
LEAD - CV # 290	Thyristor control: Sound pitch at medium speed for ELECTRIC engines From SW-version 20!	0 - 100	10	40	Percentage of the increased pitch of the thyristor sound at medium speed compared to standstill. Define the "medium speed" in CV #292. = 0: no change, pitch remains the same as at standstill. = 1- 99: corresponding change in pitch = 100: pitch doubled already at "medium speed".
# 291	Thyristor control: Sound pitch at maximum speed for	0 - 100	10	100	Percentage of the increased pitch of the thyristor sound at maximum speed compared to standstill. = 0: no change, pitch remains the same as at standstill.

CV	Designation	Value Range	INC Steps	De-fault	Description
	ELECTRIC engines From SW-version 20!				= 1- 99: corresponding change in pitch = <u>100</u> : pitch doubled at "medium speed"
# 292	Thyristor control Speed step for medium speed for <u>ELECTRIC engines</u>	0 - 255	10	100	Internal speed step defined as "medium speed" for the pitch level according to CV #290. The CV's #290 – 292 form a three-point characteristic curve for the pitch of the thyristor control sound, starting at standstill, whenever the original sample is being played back.
LEAD - CV # 293	Thyristor control Volume at steady speed for <u>ELECTRIC engines</u>	0 - 255	10	30	Thyristor control-sound volume at steady speed (no acceleration or deceleration in process). Note: sound changing to load will be set with CV's #277 and up but is not yet possible with SW-Version 4.
# 294	Thyristor control Volume during acceleration for <u>ELECTRIC engines</u>	0 - 255	10	100	Volume during heavier accelerations; the value in CV #294 should be larger than in CV #293 to be useful (so that the volume increases when the engine accelerates). At lesser accelerations a lower volume is selected automatically (exact algorithm is not finalized with SW-Version 4).
# 295	Thyristor control Volume during deceleration Motor sound of <u>ELECTRIC engine</u>	0 - 255	10	50	Volume during heavier decelerations (braking); the value in CV #295 may be higher or lower than in CV #293, depending on whether the thyristors are stressed during power feedback to the net (which increases the volume) or not (which rather decreases the volume).
LEAD - CV # 296	Motor sound, highest volume for <u>ELECTRIC engines</u>	0 -255	10	100	Maximum volume of motor sound at full speed or at the speed defined by CV #298.
# 297	Motor sound, where sound becomes audible for <u>ELECTRIC engines</u>	0 -255	10	30	Internal speed step at which the motor sound becomes audible; the sound starts quietly at this speed and reaches the maximum volume as per CV #296 at the speed defined in CV #298.
# 298	Motor sound, starting point of full volume for <u>ELECTRIC engines</u>	0 -255 (> CV# 297)	10	128	Internal speed step at which the motor sound reaches full volume; at this speed step the motor sound is played back at full volume according to CV #296.
# 299	Motor sound, Sound pitch	0 -255 (> CV# 297)	10	100	As the engine speed increases, the motor sound is also increasing in speed, according to this CV.

CV	Designation	Value Range	INC Steps	De-fault	Description
	dependent on speed <u>Electric engines</u>				= 0: Pitch (playback speed) will not be raised. = 1 .. 100: Intermediate values. = 100: Doubles pitch, > 100: same as 100 for now; reserve for SW expansion
MORE CV's belonging to this group beyond the next table (from CV #344 up)!					

The following CV's are not suitable for the "incremental programming", because they either are too difficult to test immediately (large time intervals for random generators) or single bits need to be set. They are programmed the usual way (CV # = ...).

CV	Designation	Value-Range	De-fault	Description
# 310	On/off key for engine and random sound	0 - 19, 255	8	Defines the function key (by default F8) that turns the engine sound (chuffs, boiling, blow-off's, brake squeals...) as well as the random sound (compressor, coal shoveling...) ON or OFF. = 255: engine and random sound is always ON.
# 311	On/off key for function sound	0 - 19	0	A key can be assigned with which all function sounds (i.e. F2 – whistle, F6 – bell etc.) can be turned on and off. No key is programmed for this at delivery. = 0: <u>does not</u> mean that F0 is assigned for this task but rather that the function sounds are always active. = (# 310), if the same value is entered here as in CV #310, the key defined in #310 turns all sound on/off. = 1 ... 12: Assigns separate key to turn function sound on/off.
# 312	Blow-off key	0 - 19	4 = F4	Defines a function key to play-back the blow-off sound manually (that is the same sound programmed with CV #300 = 133 to be played back automatically). For example: to do shunting with „open valves“. = 0: no key assigned (use this setting if keys are used for other purposes).
# 313	Mute key from SW version 18	0 - 19 or 101 - 119	8	This CV assigns a function key with which the driving sounds can be faded in and out, i.e. when the train becomes invisible after disappearing behind scenery. F8 is used by default, which is already the sound on/off key but now does so softly. = 0: No mute key or mute function. = 1 ... 19: Assigned function key = 101 ... 119: Assigned function key, inverted action.
# 314	Fade in/out time from SW version 18	0 - 255	0	Time in tenth of a second for sound fading in/out when mute button is pressed. Range is 25 seconds. = 0: 1 sec, which is the same as a value of 10.
# 315	Minimum interval for random generator Z1	0 - 255 = 0 - 255 sec	1	The random generator produces internal pulses in irregular intervals that are used to playback a sound file assigned to the random generator. CV #315 defines the shortest possible interval between two consecutive pulses. Sound samples are assigned to the random generator Z1 with the help of the procedure CV #300 = 101, see above! By default, the compressor is assigned to Z1. Special note to random generator Z1: The random generator Z1 is optimized for the compressor (which should be played back shortly after the train has stopped); therefore the default assignment should be retained or at the most be used for a different compressor. CV #315 also determines the proper time the compressor is started after coming to a stop!

CV	Designation	Value-Range	De-fault	Description
# 316	Maximum interval for random generator Z1	0 - 255 = 0 - 255 sec	60	CV #316 defines the maximum time interval between two consecutive pulses of the random generator Z1 (that is most often the start of the compressor); the actual pulses are evenly spaced between the values in CV #315 and #316.
# 317	Playback length for random generator Z1	0 - 255 = 0 - 255 sec	5	The sound sample assigned to the random generator Z1 (most often the compressor) is played back for the duration defined in CV #317. = 0: Sample plays once (in the defined duration)
# 318 # 319 # 320	As above but for sound generator Z2	0 - 255 0 - 255 0 - 255	20 80 5	By default, Z2 is assigned for coal shoveling.
# 321 # 320 # 323	As above but for sound generator Z3	0 - 255 0 - 255 0 - 255	30 90 3	By default, Z3 is assigned for the injector.
# 324 # 325 # 326	As above but for sound generator Z4	0 - 255 0 - 255 0 - 255		As delivered, this random generator is not assigned to any sound.
# 327 # 328 # 329	As above but for sound generator Z5	0 - 255 0 - 255 0 - 255		As delivered, this random generator is not assigned to any sound.
# 330 # 331 # 332	As above but for sound generator Z6	0 - 255 0 - 255 0 - 255		As delivered, this random generator is not assigned to any sound.
# 333 # 334 # 335	As above but for sound generator Z7	0 - 255 0 - 255 0 - 255		As delivered, this random generator is not assigned to any sound.
# 336 # 337 # 338	As above but for sound generator Z8	0 - 255 0 - 255 0 - 255		As delivered, this random generator is not assigned to any sound.
# 341	Switch input 1 Playback time	0 - 255 = 0 - 255 sec	0	The sound sample allocated to switch input 1 is played back for the duration defined with this CV. = 0: Play sample back once (as recorded)
# 342	Switch input 2 Playback time	0 - 255 = 0 - 255 sec	0	The sound sample allocated to switch input 2 is played back for the duration defined with this CV. = 0: Play sample back once (as recorded)
# 343	Switch input 3 (if not used for the cam sensor) Playback time	0 - 255 = 0 - 255 sec	0	The sound sample allocated to switch input 3 is played back for the duration defined with this CV. = 0: Play sample back once (as recorded)

Fortsetzung der CV-Tabelle bis CV # 299 !!!				
CV	Designation	Value-Range	De-fault	Description
# 344	Run-on time of motor sounds after stops (Cooling fan etc.) for <u>DIESEL and ELECTRIC engines</u>	0 - 255 = 0 - 25 sec	0	After the engine is stopped some accessories are still operating (i.e. cooling fans) and stop after the time defined here, provided the engine didn't start up again. = 0: Won't run after stop. = 1 ... 255: Runs for another 1 to 25 seconds.
# 345	Quick-select key for the sound of a <u>MULTI-SYSTEM</u> engine	1 - 19	0	Defines a function key (F1 – F19) which switches between two sound types (i.e. between an electro and diesel sound of a multi-system engine). This feature is only intended for certain sound projects (i.e. RhB Gem), where the two sound types are part of the same sound collection.
# 350	Delay of switchgear sound after start up for <u>ELECTRIC engines</u> .	0 - 255 = 0 - 25 sec	0	The switchgear on some engines (i.e. E10) should not be heard immediately after start but rather after some time defined here. = 0: Switchgear is heard immediately after start.
# 351	Smoke fan speed at steady speed for <u>DIESEL engines</u>	1 - 255	128	The fan speed is adjusted with PWM; the value in CV #351 defines the speed at steady cruise. = 128: Half of the available voltage is applied to the fan motor.
# 352	Smoke fan speed at acceleration and motor start-up for <u>DIESEL engines</u>	1 - 255	255	To generate the puff of smoke at start-up or heavy smoke under hard acceleration, the fan motor is set to a higher speed (usually full speed). = 255: Motor receives full voltage at start-up.
# 353	Automatic shut-down of smoke generator for <u>STEAM and DIESEL engines</u>	0 - 255 = 0 - 106 min	0	If the smoke generator is controlled by one of the special effects "010010xx" or "010100xx" in CV's 127 – 132 (for one of the function outputs FO1 to FO6), it will turn off automatically after the time defined here (to prevent overheating). = 0: Won't turn off automatically = 1 bis 155: Switches off automatically after 25 seconds/unit. Maximum time therefore is about 6300 sec. = 105 minutes.
# 354	Steam chuff frequency at speed step 1	1 - 255	0	CV #354 works only if used together with CV #267! CV #354 compensates for the non-linear speed measurement of the "virtual cam sensor": While the adjustment of CV #267 is done in the vicinity of speed step 10 (slow but not very slow), a correction for speed step 1 can be performed with CV #354 (extremely slow). = 0: no effect = 1 .. 127: more chuff beats in relation to CV #267. = 255 .. 128: less chuff beats.
# 355	Smoke fan speed during Stand still for <u>STEAM and DIESEL engines</u>	1 - 255	0	Addition to CV # 133 and effects with code 72 (steam engine) or 80 (diesel engine), where the fan is used only during smoke chuffs at starting and cruising. CV #355 is used to set the rotation speed of the fan during stand still so that smoke can still be emitted, just at a much lower quantity.

Fortsetzung der CV-Tabelle bis CV # 299 !!!				
CV	Designation	Value-Range	Default	Description
# 357	Thyristor control Decrease of noise during high speeds for <u>ELECTRIC engines</u>	0 - 255	0	Internal speed step at which reduction of the thyristor noise should occur.
# 358	Thyristor control Process of reduction of noise at high speeds for <u>ELECTRIC engines</u>	0 - 255	0	Process during which the thyristor noise as defined by CV #257 should decrease in noise. = 0: no reduction = 10: decreases by about 3 % per speed step. = 255: noise stops during the speed step defined by CV #257.
# 359	Control unit sound Control unit's playback time during change of velocity for <u>ELECTRIC engines</u>	0 - 255	30	Time in tenth of a second (adjustable from 0-25 sec) during which the control unit sound can be heard during velocity changes. Only functions if control unit sound exists in the sound project.
# 360	Control unit sound Control unit's playback time after stopping for <u>ELECTRIC engines</u>	0 - 255	0	Time in tenth of a second (adjustable from 0-25 sec) during which the control unit sound is still audible after stopping. = 0: after stopping not at all.
# 361	Control unit sound Waiting time until the next playback for <u>ELECTRIC engines</u>	0 - 255	20	Control unit sound would happen too often during quickly following changes in velocity. CV # 361: Time in tenth of a second (adjustable from 0-25 sec) as minimum distance between control unit playbacks.
# 362	Thyristor control Switch threshold for a second sound for <u>ELECTRIC engines</u>	0 - 255	0	Speed step during which it is switched to a second thyristor sound for higher speeds; this was introduced for the sound project "ICN" (Roco Edition) = 0: no second thyristor sound
# 363	Control unit sound Division of speed into speed steps for <u>ELECTRIC engines</u>	0 - 255	0	Number of speed steps in the entire range (stand still until max.cruising); for example if 10 speed steps are defined, the control unit sound happens during (internal) speed steps 25, 50, 75, ... (10 times in total). = 0: equivalent to 5; meaning 5 speed steps over the entire cruising range.

If the driving noise in the Ready-to-use Sound Project is too noisy ...

The easiest option is to use CV #266 to dampen the entire volume – read the actual value and program a lower value into CV #266 – thi of course affects the cruising sound and the function sounds (whistle, horn, squeals, etc.) and the last ones are usually too quiet. Therefore ...

Reduce driving noise (WITHOUT altering function sounds) for **STEAM engines**:

Read values in CV's #275, #276, #283, #286 (see CV chart for individual meaning), then program a lower value; often it is enough to modify CV's # 275 and #276, because they control non accelerating cruising speeds (and often times the sound intensity is only bothersome there).



NOTE (also for DIESEL and ELECTRIC): The default values in the CV chart often are not in use because other values are defined in the utilized sound project. This is why the actual values should always be read from the CV's and the new (usually lower) values should be programmed.

Reduce driving noise (WITHOUT altering function sounds) for **DIESEL engines**:

In this case CV's #275, #276, #283, #286 are also modified, the values are reduced to achieve a quieter driving noise.

In contrast to the steam engines, the values in these 4 CV's are the same or similar (because diesel motors do not react as strongly to the load); just in case, they should be read independently.

Reduce driving noise (WITHOUT altering function sounds) for **ELECTRIC engines**:

In this case the CV's #275, #276, #283, #286 are usually only responsible for the vent sounds (or are not used at all), but that can vary from one sound project to another.

Instead, the volume of the thyristor sounds is set through CV's #293, #294, #295 and the motor sounds through CV #296 (for a detailed description see CV chart). The actual values of those CV's must be read and replaced with lower values

Update Project files (Function mapping, Function-Sound-Assignment) with ZIRC

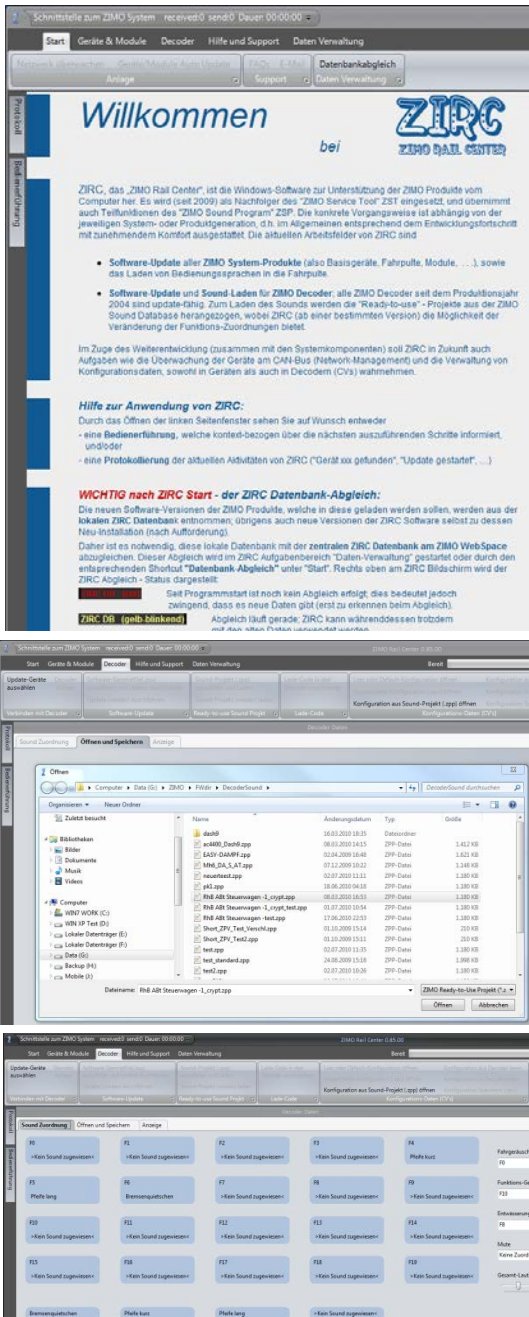

Quick Guide (outline):

ZIRC is used "offline", meaning no decoder update equipment, decoder, or other product must be connected to a computer.

In this case, the project files are updated, this refers to .zpv files or .zpp files; usually .zpp files, also know as "Ready-to-use" sound projects.

The CV list, which contains among others the CV's for function mapping and special effects (american light effects, smoke generators, etc.) as well as the assignment of the functions (function keys) are in the project files in the sound samples of the project.

Do not change or exchange the sound samples here on your own!

- In the start selection on the welcome screen (tab after "equipment and modules" or "decoder") choose "decoder".
- After that, a page will appear with detailed descriptions of the ZIRC task that are related to the decoder. The described scope of functions configuration values (CV's) (upper right hand corner) and other ZIRC task areas that are responsible for software updates and loading sound projects are found here.
- Now start "Configuration from Sound Project (.zpp) open" from the task area of the "Decoder Configuration Values".
- This opens a sub-window with register cards where the area "Open and Save" is chosen. The desired "Ready to use Sound Project" (.zpp file) is chosen in the open selection window.
- Afterwards the register cards "Assign sound", "Function mapping" and "Update CV-List" can be used.
- In "Assign sound", drag the individual sound samples (their designations) with the mouse to the desired function keys even those that have never been assigned (small fields below); "empty" means that the function should not cause a sound. As the On/Off key and other general parameters are assigned here.
- "Function mapping" offers a comfortable, specially designed support for ZIMO decoders for function mapping, for setting the CV's according to the demands of the model and the desires of the user. The function effects are also assigned under these parameters.
- In "Open and Save" the modified sound project can be saved under a new name (or the old one).

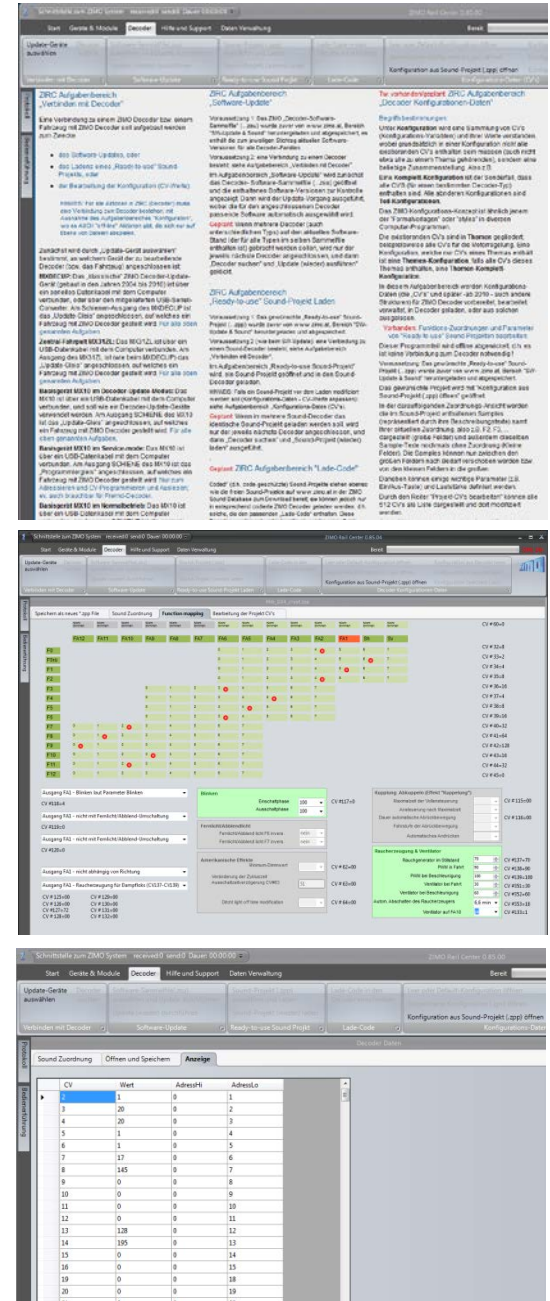

Software-Update ZIMO Decoder, Loading Sound Projects with ZIRC

Quick Guide (outline):

ZIRC in this case is used together with MXDECUP with MX31ZL (in the future with MX10).

- In the start selection on the welcome screen (tab after "equipment and modules" or "decoder") choose "decoder".
- Afterwards the user decides whether to,
 - prepare data (task area Configuration Values, CV's) see outline above!
 - or
 - perform SW updates by loading "ready to use" sound projects ("**connect with decoder**")

ZIRC builds a connection to the connected update device (MX31ZL, MXDECUP, MX10, ..) and shows the connection. Afterwards the decoder that is automatically connected to the update device is identified.

Now select if a "**decoder update**" or "**load sound project**" should be conducted (not both at the same time!).

The decoder software collector file can be downloaded automatically from the ZIMO WebSpace (if the computer has an internet connection) or select the previously downloaded file from the computer (or USB stick) and from there can be brought into ZIRC.

To load a ready to use sound project, look for and select the prepared .zpp file. The file will automatically load in the decoder once it is opened.

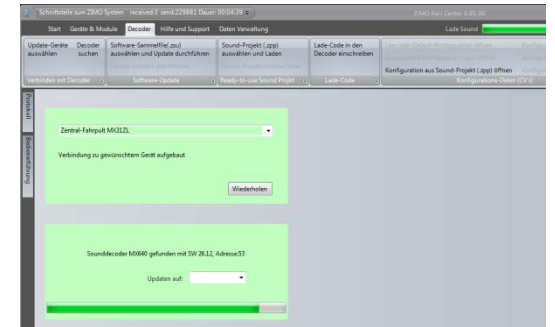
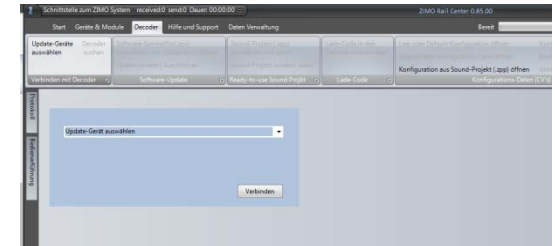
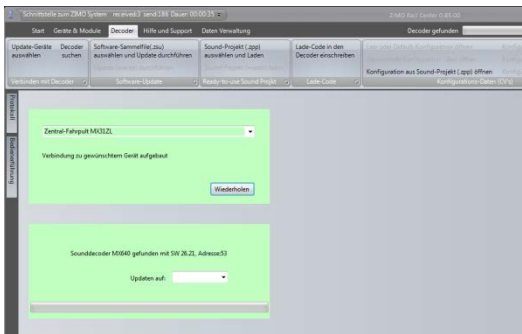

ATTENTION:

Previously sold
decoder update units **MXDECUP**
need to be modified
to deliver higher power for the **MX695!**

